

Compact Automated Waste Sorting System (CAWSS)



University of Central Florida
Department of Engineering and Computer Science

Dr. Lei Wei, Samuel Richie, and Aravinda Kar
EEL 4914: Senior Design 1

Group 1

Melissa Siver

Photonic Science and Engineering

Troy Rzeznikiewicz

Photonic Science and Engineering

Clyde Bujari

Computer Engineering

Juan Soto

Electrical Engineering

Table of Contents

1 - Executive Summary	1
2 - Goals, motivations, and objectives motivation	3
2.1 - Introduction	3
2.2 - Motivation	3
2.3 - Function of Project	4
2.4 - Goals	5
2.5 - Objectives	6
2.6 - Requirements Specifications	7
2.6.1 General Requirements	7
2.6.2 Housing	7
2.6.3 Delivery Mechanism	8
2.6.4 Spectrometer	8
2.6.5 Sensors	8
2.6.6 Processor	8
2.6.8 Power	9
2.7 - House of Quality (HOQ)	11
2.7.1 HOQ Technical Requirements (“Quality Characteristics”)	12
2.7.2 HOQ Marketing Requirements (“Demanded Quality”)	12
2.7.3 HOQ Discussion/Analysis	13
2.8 - Initial Block Diagrams	17
3 - Research Related to Project Definition	18
3.1 - Existing Similar Projects and Products	18
3.1.1 - Voluntary Non-Automated Multi Stream Can Solutions	18
3.1.2 - Handheld Spectrometers for Plastic Detection	19
3.1.3 - Industrial Spectrometry Waste Sorting	21
3.1.4 - Previous Waste Sorting Senior Design Applications	22
3.2 - Relevant Technologies	23
3.2.1 - Optical Fibers	23
Fiber Basics	23
Single mode Vs Multimode Propagation	24
Index Profiles	24
3.2.2 - Spectrometers	25
Types of Spectrometers	25
Spectrometer Layout	26

3.2.3 - Sensor Technology	26
Passive Sensors	26
Active Sensors	27
Figure 12. Active vs passive sensing. (Permission Pending)	27
3.2.4 - Infrared Light Sources	27
3.2.5 - Light Focusing Elements	28
3.2.6 - Solar Panels	30
Functionality and Availability	30
3.2.7 - Processors	32
Field-Programmable Gate Array (FPGA)	32
Single-Board Computer (SBC)	33
Microcontroller (MCU)	33
3.2.8 - Batteries	34
3.3 - Strategic Components and Parts Selection	34
3.3.1 - Fiber Selection	34
3.3.2 - Spectrometer Selection	36
3.3.3 - Light Source Selection	37
3.3.4 - Light Focusing Element Selection	43
3.3.5 - Delivery Mechanism Selection	45
Conveyor Belt System	45
Conveyor Belt Material Options	45
Chute System	46
3.3.6 - Sensor Selection	46
IR Sensors	47
Color Sensor	47
Design Matrix for Sensors	48
3.3.7 MCU Selection	48
MCU Options	49
3.3.8 - SBC Coprocessor Selection	51
Technical Requirements and Specifications	51
Generalized Design Matrix for Processors	52
3.3.9 Voltage Converter Selection	53
3.3.10 Solar Panel Selection	54
3.3.11 Solar Panel Accessory Selection	56
Battery Selection	56

Charge Controller Selection	57
3.4 - Possible Architectures and Related Diagrams	57
3.5 Optical Component Selection Summary	59
3.5.1 Spectrometer Input Requirements	59
3.5.2 Fiber Selection	60
3.5.3 Lens Selection	60
3.5.5 Final Incident Light Calculations	61
3.5.6 Zemax Test Plan	62
3.6 - Parts Selection Summary	63
4 - Related Standards and Realistic Design Constraints	64
4.1 - Standards	64
4.1.1 - Power Supply Standards	65
4.1.2 - PCB Standards	65
4.1.3 - Power Electronic Converter Systems	66
4.1.4 - Requirements for Battery Chargers	66
4.1.5 - Solar Photovoltaic Power Supply Systems	66
4.1.6 - Plastics Recycling Standards	67
4.1.7 General Recycling Standards	67
4.2 - Realistic Design Constraints	68
4.2.1 Economic and Time Constraints	68
4.2.2 Environmental, Social, and Political Constraints	70
4.2.3 Ethical, Health, and Safety Constraints	71
4.2.4 Manufacturing and Sustainability Constraints	72
5 - Project Hardware and Software Design Details	74
5.1 - Initial Design Architectures and Related Diagrams	74
5.1.1 - Design Mock-Up	74
5.2 Decision Matrix	75
5.3 Analysis of Decision Matrix	76
5.4 - Delivery Subsystem	76
5.5 - Optical Component Subsystem	79
5.6 - Conveyer Subsystem	81
5.6.1 - Conveyer Belt	81
5.6.2 - Sensor Placement	82
5.6.3 - Flapper	82
5.7 - Breadboard Test and Schematics	83

5.8 - Software Architecture	84
5.8.1 MCU Software Architecture	84
Main Function and Power-Saving Mode Discussion	85
Sensor 1 ISR	86
Sensor 2 ISR	86
Analysis Result ISR	86
5.8.2 Raspberry Pi Software Architecture	87
Discussion of Spectral Analysis	88
Spectrum Database	89
5.9 - Power Subsystem	90
5.10 - Housing Subsystem	91
5.10.1 - CAWSS Housing	91
5.10.2 - Optical Suspension	92
5.11 - Summary of Design	92
6- Project Prototype Construction and Coding	93
6.1 - Integrated Schematics	93
6.2 - PCB Vendor and Assembly	97
6.3 - PCB Design	98
6.4 - Final Coding Plan	101
7- Project Prototype Testing Plan	103
7.1 Hardware Specific Testing	103
7.1.1 Spectrometer Testing	103
7.1.2 Light Source Testing	105
7.1.3 Spectral Analysis Testing	107
7.1.4 Lens Testing	109
7.1.5 Sensor Testing	110
7.1.6 Conveyor Belt Testing	111
7.1.7 Trash Chute Testing	112
7.1.8 Flapper Testing	113
7.1.9 Power System Testing	114
7.1.10 PCB Testing	114
7.1.11 Servo Motor Testing	115
7.2 Software Environment	116
7.3 Software Testing	117
MCU Software Testing	117

Raspberry Pi Software Testing	118
8 - Administrative Content	120
8.1 - Milestones	120
8.1.1 - Class Milestones SD2	121
8.1.2 - Team Milestones	121
8.2 - Initial Budget and Financing Discussion	122
8.3 Parts Acquisition and Bill of Materials (BOM)	123
8.3.1 Acquisition of OceanInsight Flame NIR Spectrometer	123
8.3.2 Acquisition of SMA-to-SMA Fiber Optic Patch Cable	125
8.3.3 Acquisition of Lens	125
8.3.4 Acquisition of Light Source and Housing	126
8.4 Project Roles	127
8.5 Project Design Challenges	128
8.6 Looking Forward	130
Bibliography	133
Appendix A - image permissions	139

Table of Figures

Number	Description	Page
1	Generalized Flowchart for CAWSS Systems & Processes	17
2	High-Level CAWSS Software Flowchart.	18
3	Standard multistream trash can	19
4	ThermoFisher PC Analyzer	20
5	trinamiX handheld sorting solution	20
6	LLA KUSTA camera setup	21
7	Tomra Automatic Waste Sorting System	21
8	BioRhythm PCB spectrometer design	22
9	Anatomy of an optical fiber	23
10	Diagram of fiber profiles	25
11	Traditional spectrometer design	26
12	Active vs passive sensing	27
13	Visual representation of Wein's Law	28
14	Simple ray trace of concave mirror	29
15	Ray traces associated with various lens shapes	30
16	Function of a photovoltaic cell	31
17	The sun's emission spectrum	38
18	Absorption and reflectance spectrums taken with Cuda	40
19	250 W Halogen Sample Spectra	48
20	Worklight testing setup	41
21	60 W Incandescent Sample Spectta	42

Table of Figures (cont.)

Number	Description	Page
22	Rough Raytrace with Mirror	43
23	Sensor Positioning Diagram	46
24	Initial CAWSS design	58
25	Second initial CAWSS design option	59
26	CAWSS CAD Rendering	74
27	Internal CAWSS Diagram	74
28	45 Degree Optical Sorter	77
29	Relay Breadboard Test	83
30	Generalized Software Architecture Flowchart	84
31	ATMega2560 Power State Characteristics	85
32	Preliminary analysis software in manual/debug mode	87
33	Relay Circuit Schematic	94
34	Spectrometer Driver Power Schematic	95
35	Microprocessor Power Schematic	95
36	Microprocessor Interconnection Schematic	96
37	Integrated Circuit Schematic	96
38	Hand Drawing Vs. Eeschema Part	98
39	Ultra Librarian Footprint	99
40	PCB Design	100
41	PCB Design 3D View	101
46	Team Milestones with Executable Steps	121

Table of Figures (cont.)

42	OceanInsight Flame NIR Spectrometer	124
43	Thorlabs Step-Index Multimode Fiber Optic SMA-to-SMA Patch Cable	125
44	Thorlabs N-BK7 Plano-Convex Lens	126
45	Various light source bulbs	116

Table of Tables

Number	Description	Page
1	Summary of specifications	10
2	House of Quality Specification Matrix	11
3	Comparison of considered fibers	36
4	Comparison of Spectrometer Options	37
5	Comparison of Possible Light Sources	42
6	Technical requirements for device sensors	47
7	Design Matrix for Sensors	48
8	Technical requirements for MCUs	49
9	Relevant MCU Technical Specifications	50
10	Generalized Design Matrix for MCUs	50
11	Generalized Technical Requirements for SBC	51
12	Relevant Processor Technical Specifications	52
13	Generalized Design Matrix for Processors	52
14	Comparison of Solar Panel Options	56
15	Battery Runtime and Cost Summary	57
16a	Part Selection Summary A	63
16b	Part Selection Summary B	64
17	Decision Matrix	75
18	Senior Design 1 Milestones	121
19	Senior Design 2 Milestones	122
20	Estimated budget for optical parts	122

Table of Tables (cont.)

21	Estimated budget for electrical interface parts	123
22	Estimated budget for housing and conveyor parts	124

1 - Executive Summary

Pre-factory separation of recyclable materials from waste is seldom pursued outside of private households. Any attempts made to address this issue in public spaces are centered around multi-stream waste cans that require manual separation. The average individual has only basic knowledge of what materials are recyclable; without proper care much waste can go incorrectly sorted or simply not sorted at all. Incorrect waste identification can result in hefty taxpayer losses and unrecycled resources. The Compact Automated Sorting System (CAWSS) brings to light a solution that has not yet been considered: the application of near-infrared (NIR) spectroscopy to public waste bin disposal. The CAWSS seeks to educate the public, reduce incorrect recycling identification, and promote alternative energy sources all at once.

The CAWSS offers in-line identification of both recyclable and non-recyclable material, and utilizes a streamlined near-infrared spectroscopy-based system in conjunction with a conveyor delivery mechanism to sort waste into the appropriate bins. The contents of the CAWSS can then be removed by employees for appropriate disposal and ultimately proper processing and re-use. Solar powered components allow the CAWSS to present a model of “absolute green-ness,” as it is both self powered and self contained. This earth-friendly product is offering its debut just as the climate crisis comes to the forefront of modern life. The CAWSS is emerging as a competitive future participant in the developing green economy.

The CAWSS offered distinct design challenges to the development team. Appropriate light emissions from an affordable source were extensively tested to balance power consumption and lumen emission. Different waste geometries offered widely varying angles of reflectance, and required a special chute mechanism to be designed for optimal trash incidence. Solar panel space requirements forced creative panel placement and thoughtful charging solutions. Each one of these challenges added to the CAWSS’s appeal via the development team’s resourceful and distinct solutions.

The development team’s self-written spectroscopy software offers a user-friendly, easily automated program for waste identification. This interface seeks to educate users through presenting identification of waste quickly and in an easily-understood manner. Once identification has been executed, the code sends the results of this analysis to the microcontroller, which then uses the internal flapper to guide waste into the appropriate bin. This elegant two-in-one functionality fulfills both the goal of education and of correct waste identification.

The CAWSS utilizes an Ocean Insight Flame NIR spectrometer. This project was made possible by Ocean Insight’s sponsorship. The CAWSS’s ability to offer a

modern solution to the long-standing waste sorting issue is made possible by the Flame's accuracy and quick response time. Future implementations of the CAWSS will strongly encourage the use of this spectrometer for ease of implementation and dependability in operation.

The CAWSS has the potential to become a trailblazing idea in public waste sorting solutions. No widely available general-use trashcan offers even a fraction of the functionality of the CAWSS - and, certainly, none serves to educate end users. The CAWSS team hopes this product can demonstrate the green possibilities that can be achieved with our cutting-edge design and forward-thinking goals.

2 - Goals, motivations, and objectives motivation

In engineering design, it can become very easy to lose focus of the bigger picture by getting caught up in technical details. Motivations are the driving factor that pushes individuals and teams to forever break through boundaries and continue to push design further. Goals are checkpoints that help teams be able to visualize the finish line in order to give people the push that is needed sometimes. Objectives are quantifiable things that will need to be done with accuracy, quality, and precision to be able to reach those goals.

2.1 - Introduction

Identifying post-consumer waste as a recyclable material can be a very daunting task for the average individual and the consequence of misidentifying waste can further complicate the waste sorting process. Not only does misidentified waste decrease efficiency of the waste sorting process, these pieces have to be individually picked out by employees which can slow down the rate at which the sorting facility processes recyclables. This can also lead to many other problems such as damage to equipment, cross contamination of other recyclable materials, and environmental issues.

Our team plans to eliminate this issue by developing a compact waste sorter that can be used anywhere that there is a waste bin for post-consumer waste. We will eliminate human error when designating an item as recyclable or non-recyclable by obtaining the spectra of the item in question, using software to aid in the assessment of recyclability, and then feeding it into its appropriate destination within the bin. This will be self-contained in a structure that will house a conveyor belt for moving waste, a near-infrared spectrometer for obtaining a spectral reading, and a flapper for physically moving the waste to its appropriate destination. This process will utilize energy recovery in the form of solar panels to reduce its carbon footprint.

2.2 - Motivation

As humans, disposing of waste daily is an inevitable fate that is often met with the option of placing an item into a recycling bin or a trash bin. We face the question of “Is this able to be recycled?” almost every day, which many times ends up in something called wishful recycling; the process of tossing non-recyclables in the recycling bin hoping for them to be recycled. While most people assume identifying a waste item as trash or recyclable is easy, it can be quite troublesome for others. The process of identifying materials as recyclable can be even further complicated when local and state guidelines change the criteria for recyclability. This problem is further exasperated when consumers travel outside of their natural environment and are under a different set of local

guidelines for recycling. This can appear to be a careless mistake but it actually can have a significant impact on the efficiency of the recycling process.

Wishful recycling has recently been identified by organizations such as the Sierra Club and the Watershed Project as one of the biggest threats to the long term sustainability of recycling programs in the United States. Additionally, a case study done in Arcata, California estimates that 25% of the waste that comes through their recycling facility ends up in a landfill with an average cost of \$12 per customer each year as a result of the extra sorting time it takes. This evidence makes it clear that people are not as good as they think at making informed decisions on the recyclability of their waste. Not only are these mistakes costly to the recycling facilities that then have to hand-pick and ship these non-recyclable materials to other processing facilities, these materials can also contaminate potentially recyclable materials which even further intensifies the need for a better recycling system.

Current designs of trash and recycling cans have been almost unchanged in the past 4 decades. Our team believes that not only would a design change be advantageous, it would have a significant impact on the future of recycling by erasing some of the biggest challenges pertaining to the sorting waste. The design of our system brings peace of mind to the user that their post-consumer waste is almost guaranteed to go to the correct destination, resulting in a more profitable, efficient, and sustainable recycling program.

Our design team intends to solve this problem using fairly understood optical sorting methods that can be applied to a compact waste sorting system. We not only intend to minimize the amount of non-recyclable items that enter the waste sorting system each and every day but we also aim to replace conventional dual-purpose trash and recycling bins with our Compact Automated Waste Sorting System, otherwise known as CAWSS. The total size of our system would be roughly the same cubic size as a conventional trash can. This system will be capable of differentiating waste items with a high degree of accuracy to ensure an increase in the efficiency of the waste sorting process. This will all be achieved through the use of Near Infrared Spectroscopy (NIRS) being implemented with custom software to identify and compare emission spectrums of a multitude of materials. Our system will then physically sort the waste item through the use of a conveyor belt, a flapper powered by servo motors, and a gravity chute.

2.3 - Function of Project

The primary function of this project is to be able to develop an apparatus capable of screening materials, designating them as recyclable or non-recyclable, and sorting them into their destination. With this, we plan to

reduce human-error and be able to increase the efficiency of sorting facilities. This will not only take the burden off of the user to spend time deciding if an item is recyclable but it also will have many benefits in sorting facilities, as mentioned above.

The first function of our system would be to accurately sort materials apart from each other based on recyclability. Our highest probability of success in relation to our budget and time to develop would be to utilize Near Infrared Spectroscopy (NIRS) in combination with a software program in order to accurately separate trash from recyclable materials. Another function of our system would be to physically separate the materials into their appropriate designations by the means of a conveyor belt. The conveyor belt functions as a mechanism that would move the waste from its entry point, through the spectrometer, and then into the appropriate bin. On the end of the conveyor belt, a flapper powered by a motor will function as the sorting mechanism that will push the waste into the trash bin or the recycling bin.

2.4 - Goals

The primary goal of this project is to create a functional optical sorter that can be used anywhere that there is a waste bin for post-consumer waste. Our largest goal is being able to successfully obtain a spectra of waste items using spectroscopy that will utilize software to compare the spectra of test items against known recyclable materials. We plan on using NIR (near-infrared) spectroscopy to obtain these readings. The items will be fed into the bin from a hopper onto a conveyor belt where a spectral reading will be taken of the item as it passes. After this, software will aid to make a decision where a flapper will then push the waste to either the recycling or non-recycling side of the waste bin. This will allow sorting facilities to run at higher processing rates as well as avoid cross contamination from non-recyclable items.

When comparing our system to the industry standard, portability is a large selling point for some of the most popular designs of current waste bins being used. Portability and ease-of-use is a very important design factor for our team as we continue to develop our design. This will allow for our system to be no less portable than current waste bins being used, allowing for people to move our system around the same as they would a normal waste bin. By making our system portable, this could provide us with a unique advantage over several non-portable waste bins that are commonly used in public.

We aim to make this compact sorter as user-friendly as possible while maintaining a relatively high degree of accuracy. One of the ways we are going to be able to achieve user friendliness with our device is to have the device on standby until a piece of trash is detected by the sensor in which case the

process would start. This would allow for the consumer to use our system in the same manner as a conventional waste bin without the need for identifying the item they are throwing away. The only user input required will be the trash placed in the system. We also intend to make this system user-friendly for the people that will be emptying it as well as any maintenance or minor repairs that need to be completed.

Another primary goal our team has for our project design is to implement technology into the design that we believe has the possibility of being manufactured for cheaper in the future based on the scale of production. It is not our intention to produce a system for research of plastic emission spectrums but rather we intend to produce a system that can function, compete, and accomplish what other waste containers currently do not. In order to achieve this, we will be choosing components and technologies that are commonly used and have the potential of being built either in-house or sourced for a lower cost as the design becomes more refined.

Eye safety is of the utmost importance when it comes to integrating optics into commonly used products such as our own. Although it is possible to obtain more accurate spectral readings using destructive or non-eyesafe techniques, part of the reason why we chose NIR spectroscopy was because of the limited risk it carries to the consumer when using the device. Not only will this ensure our team's safety in the design and production stages of our system, it will also ensure the consumers safety while making the possibility of FDA compliance much simpler as it will be using eyesafe techniques.

Lastly, our long term goal is to have this system partially solar powered to offset the energy consumption when in operation. This will be achieved by using solar panels mounted to the system which will be in operation when the system is used in an outdoor application, enabling additional energy recovery to an already more environmentally sustainable method of recycling. While we understand that powering this entirely from solar panels may be unfeasible in our current design stage, we are designing the system to utilize less power via standby mode and energy efficient components with hopes of one day powering the system entirely through renewable sources.

2.5 - Objectives

When considering the objectives necessary in order to confidently achieve our goals, we tried to consider it from a technological and financial standpoint that would best reflect our priorities. Below are several objectives that will better help us reach quantifiable goals throughout our design process. While many of these objectives could be improved upon in the future, these are the minimum objectives needed to obtain proof of concept and a working prototype under our

current design constraints. Specifications to be met by this project are summarized in table 1.

1. We are determined for the cost of our project budget of materials to be under \$1,500.00 not including the cost of time spent in development, production, and testing.
2. We are determined to be capable of obtaining an emission spectrum of 1000-1600 nanometers in order to properly differentiate materials.
3. We are determined to have the system operating in standby mode with a power consumption of less than 10 Watts.
4. We are determined to obtain partially power our system by using solar panels
5. We are determined to achieve a 95% rate of accuracy in properly identifying qualifying materials that passes through our system
6. We are determined to complete the final prototype of our system by the end of Senior Design 2 in December, 2021.

2.6 - Requirements Specifications

These requirements should be met for CAWSS to function properly.

2.6.1 General Requirements

This device should implement the following general behavior, in two main modes:

- Standby mode
 - Conserve power while idle.
 - When trash input is detected, return to active mode.
- Active mode
 - Move/align trash to spectrometer.
 - Analyze the trash to classify it.
 - Direct trash to its correct destination.
 - Return to Standby mode.

2.6.2 Housing

The housing of the device should:

- Have two separate compartments for plastics and non-plastics.
 - Allow easy access to these compartments to empty them.
- Have enough space to fully enclose all components of the design.
- Include an isolated space for spectral analysis, minimizing external light sources.

2.6.3 Delivery Mechanism

The device's conveyor belt should:

- Be large enough to accommodate the types of trash we expect to deal with.
- Move slowly enough to allow for accurate spectral analysis.
- Consume as little power as possible.

2.6.4 Spectrometer

The spectrometer used in this device should:

- Be able to detect transmission spectra between 900 and 1600 nm.
- Be able to provide an accurate spectrum with enough resolution to differentiate plastics from other waste.
- Be resistant to water and waste materials
- Be able to be operated with low power
- Cost under 800\$
- Be able to resolve spectra within reasonable amount of time
- Maintain and control thermal stability
- Meet electrical safety standards
- Proper labeling with safety specifications

2.6.5 Sensors

Sensors in this device, other than those used for spectral analysis, should:

- Detects when a user interacts with the device while in standby mode.
 - Trigger a processor interrupt event when this occurs.
- Detect when trash on the conveyor belt approaches and exits the spectrometer system.
 - Begin and end analysis on these triggers.

2.6.6 Processor

The processor used for this device should:

- Provide sufficient analog/digital input for spectral data and all other sensors.
- Provide sufficient output to control motors and spectrometer light sources.
- Provide sufficient memory/processing power to analyze spectral data.
- Provide a low-power mode (LPM) and input-based interrupts to exit this mode.

2.6.7 Software

The software implemented on this device should:

- Exit Low Power Mode (LPM) when interrupted by sensor activity.
 - Exit processor LPM.
 - Activate spectrometer light source.
 - Start belt motor.
- Correctly classify trash based on received spectral data.
 - Stop the belt motor once trash arrives at the spectrometer.
 - Take a reading at each NIR wavelength.
 - Take a reading, then move the photodiode to the next sensing position.
 - Determine if these readings are similar enough to that of known plastics (within a certain threshold) to classify them as plastics.
- Start belt and set servo to direct analyzed trash to its correct destination.
- Turn off belt and the spectrometer's light source.
- Return to processor LPM.

2.6.8 Power

This device's power subsystem should include:

- A battery system, which should:
 - Provide sufficient power to sensors, control devices, and processors.
 - Allow the battery to be charged safely, disabling charging when near-full.
 - Include DC-DC converters to provide the required voltage for each device component.
- A solar panel system, which should:
 - Slowly charge the device's battery system in sunny weather.
- Standard US AC 110-120V input system, which should:
 - Provide a backup power source in places with little/intermittent sunlight.
 - Slowly charge the device's battery system.
 - Include an AC-DC voltage converter (eg. 20V 60Hz AC to 12V DC) to provide usable power to device components.

Type	Specification
Demonstrable Specification	Light source outputs spectrum between 2000 and 3000 K.
Demonstrable Specification	Spectrometer accurately reads spectrums of incoming waste within 10 seconds.
Passive Specification	Optical system can operate in the 900-1700 nm range.
Demonstrable Specification	Program has an execution time of less than 1 second.
Demonstrable Specification	Total sorting time per item is less than 30 seconds.
Demonstrable Specification	Solar charged battery provides 250 watts of power in an hour of operation.
Demonstrable Specification	Using less than 400 Watts of energy when in active mode

Table 1. Summary of specifications for project

2.7 - House of Quality (HOQ)

Legend													
⊙	Strong Relationship	9											
○	Moderate Relationship	3											
▲	Weak Relationship	1											
++	Strong Positive Correlation												
+	Positive Correlation												
-	Negative Correlation												
▼	Strong Negative Correlation												
▼	Objective Is To Minimize												
▲	Objective Is To Maximize												
X	Objective Is To Hit Target												
Row #	Max Relationship Value in Row	Relative Weight	Weight / Importance	Quality Characteristics (a.k.a. "Functional Requirements" or "Hows")	Column #								
					1	2	3	4	5	6	7	8	9
					Direction of Improvement: Minimize (▼), Maximize (▲), or Target (X)								
					Power source	Spectrometer	Microcontroller	Software	Sensor	Motors	Delivery Mechanism	Lighting	Housing
1	9	25.0	5.0	Accuracy/Reliability	○	○	▲	○	▲	▲	○	○	○
2	9	17.5	3.5	Range of Detection	▲	○	▲	○	▲	▲	▲	○	▲
3	9	12.5	2.5	Power Usage	○	○	▲	○	▲	○	○	○	▲
4	9	20.0	4.0	Component Cost	○	▲	○	▲	▲	▲	○	○	○
5	9	15.0	3.0	Development Time	▲	○	○	○	▲	▲	○	▲	○
6	9	10.0	2.0	Durability	▲	○	▲	▲	▲	▲	○	▲	○
7													
8													
9													
10													
Target or Limit Value													
Difficulty (0=Easy to Accomplish, 10=Extremely Difficult)					6	10	9	8	3	5	7	5	6
Max Relationship Value in Column					9	9	9	9	1	9	9	9	9
Weight / Importance					290.0	605.0	380.0	435.0	100.0	200.0	550.0	700.0	510.0
Relative Weight					7.7	16.0	10.1	11.5	2.7	5.3	14.6	18.6	13.5

Table 2. House of Quality Specification Matrix

2.7.1 HOQ Technical Requirements (“Quality Characteristics”)

- **Power Source (-):** Power system for all system components. Should be kept to the minimum that satisfies power usage requirements.
- **Spectrometer (+):** All components directly involved in spectral analysis (ie: FlameNIR, lenses, fiber optics) - performance of these components should be maximized as necessary to ensure accuracy, though this will increase component cost.
- **Microcontroller (+):** Responsible for running device’s software and commanding all connected interfaces. Performance of this component should be maximized to ensure performance, within the constraints of our budget.
- **Software (x):** Collects and analyzes spectral data to determine trash type, uses other sensor data to control motors and delivery mechanism. Meeting target specifications will help avoid unnecessary stress to components.
- **Sensors (x):** Separate from sensors used for spectral analysis, used to detect arrival of an object at certain points in the device’s process. Meeting this specification helps meet many marketing requirements, but should not exceed it to avoid increased cost/development time.
- **Motors (x) :** Used to drive delivery mechanisms. Meeting of target spec ensures reliability of many other components.
- **Delivery Mechanism (+):** Used to move trash to the sensing area and then to its correct destination. Meeting or improving on this spec will help reduce power usage and unnecessary development time,
- **Lighting (x):** Spectrometer light source. Meeting target specification ensures desired performance, helps improve durability.
- **Housing (x):** Housing for components. Meeting target specification ensures required durability, improves spectrometer’s range of detection, and helps reduce unnecessary cost on other components.

2.7.2 HOQ Marketing Requirements (“Demanded Quality”)

- **Accuracy/Reliability (5.0):** The device must produce accurate analysis of inputs, and reliably send items to their correct destinations.
- **Range of Detection (3.5):** The spectral components of the device must be able to take measurements throughout the near-infrared band, as required for accurate analysis of plastics.

- **Power Usage (2.5):** The device's power usage should be minimized where possible. While in standby mode, the device should use very little power until input is detected. In the active state, power usage should be kept well within the maximum specification of the device's power supply.
- **Component Cost (4.0):** The cost of the device's components should be minimized, both to save us money as a team and to present a more economically feasible finished product.
- **Development Time (3.0):** While we expect this to be a long-term project, we wish to ensure we have ample time to meet our goals and allow for any unexpected delays.
- **Durability (2.0):** The device should be made durable, especially to protect more sensitive and delicate components from physical shock.

2.7.3 HOQ Discussion/Analysis

The house of quality is a conceptual matrix developed in Japan during the decade of the 70's. The purpose of this tool is to exhibit how the customer's demands directly relate to the components and technology within a product. The conceptual map reveals which components are strongly or loosely tied to each essential requirement demanded by the client. Additionally, the visual matrix displays the correlation among the product's components, showing which parts are indirectly essential for multiple requirements.

A well-developed House of Quality analysis is extremely important as it highlights the components which must be developed with greater focus for the product to meet all requirements simultaneously. Without a House of Quality analysis, an essential constituent of the product might appear to play less of a critical role in the performance of the product, or a substantial portion of the resources might not be allocated to the pertinent components. For instance, the House of Quality analysis for the Compact Automated Waste Sorting System (CAWSS) revealed the lighting of the machine was of utmost importance, a fact not initially perceived by some members of the development team.

The House of Quality diagram works by first surveying and then ranking the product's requirements in order of relevance. For the CAWSS, the developers stipulated the accuracy of the detection was of paramount importance, even if higher costs were to be incurred. As a result, the accuracy requirement of the machine has a higher relevance than cost, range of detection, and development time, among others. Once the requirements of the product are properly weighted, the relationship between the individual components in the machine and each requirement must be established using a score system. Given the

requirements are weighted, components that have a strong relationship to different requirements will not tally up the same score. The relationship among all components and the requirements is then determined, and a score is therefore achieved; this score will determine the relevance of each component in terms of the product requirement.

Additionally, in the upper part of the matrix, a correlation between all components in the product must also be established in terms of how a component is dependent or interlaced to another. Although this section of the diagram does not contribute to the relevance score of a component, it provides an insight to the engineers on how a less relevant component must be further developed if it is strongly correlated to another key component in the machine. We will proceed with the House of Quality analysis by reviewing the components in order of importance.

As discussed above, the lightning achieved the highest relevance score out of all elements in the machine. This is due to the strong relationship of this component with the most important requirements: accuracy, component cost, and range of the machine. Furthermore, lightning has the most correlations with other components in the system besides the microcontroller. Although the spectrometer can be thought as the core of the machine, it requires a controlled environment that is fabricated by the light source, lens, and fiber; the interaction between these components and the spectrometer is a system that must be first designed and refined. Since these expensive components also directly affect the development time and power consumption of the portable machine, the engineers acknowledged the lightning system must receive a higher degree of attention than previously thought.

Moving on, the spectrometer scored second place in the House of Quality diagram. The level of control the team achieves over this unit will determine the ultimate accuracy, cost, and range of materials that can be sorted (the three most important requirements). Given the machine's lighting is set up correctly, the spectrometer unit becomes the heart of the machine due to the strong links with the essential requirements and, as a result, the spectral sensing unit requires a considerable allocation of time and resources. The sensing unit is not an automated subsystem of the CAWSS, meaning the spectrometer only captures the infrared activity and therefore the identification of materials from spectrum, managing noise & interference, and handling of data are all tasks of the engineers.

The delivery mechanism of the machine, or the third component in terms of score, must be adequately designed to relieve some of the issues that might arise from the task mentioned above. The delivery system is closely related to

the accuracy of the machine and moderately related to all other requirements (except the range of detection), which justifies the relevance of this component. Failing to streamline the delivery of waste to the designated detection area might make the identification of materials more challenging and will in turn interfere with the sorting process (the detection area will be aligned with the sorting area).

Furthermore, the delivery system is operated via two electric motors that will expend more energy if waste must be realigned with the sensor. This wasted energy compounds with additional enabled time of the lightning and spectrometer. The delivery system must be constructed with an approach that does not interfere with accuracy and power usage, while meeting the cost and development time requirements. Fabricating a precise and effective conveyor belt system is of utmost importance once the spectrometer and lightning fundamentals are secured.

Furthermore, the CAWSS's conveyor belt delivery mechanism must be designed with the housing in mind. The internals of the machine, and specially the spectrometer unit, must be covered from the environment while allowing the system to operate in a different number of outdoor conditions. More importantly, the housing must not interfere with the accuracy of the of spectrometer which is the most relevant requirement; the lightning and spectrometer must be calibrated to operate in such enclosure. Shielding the system might originate the risk of vibrations & interference, heat buildup in warm climates, and might escalate cost and development time when waterproofing the housing since the spectrometer must be protected from potential spills.

Due to the points described above, it is clear the housing has a considerable correlation with the delivery system since both components share a strong relationship with the same requirements of accuracy, cost, development time, and durability. These mutual requirements indicate the engineers must not only develop both components with each other in mind, but also synergy has to be instituted between them.

Another two components that carry a strong correlation with one another are the software and the microcontroller, the next two components in the ranking. The software, or logic of the microcontroller, is responsible for handling the spectrometer's data while operating the other systems without any errors. A good elaboration of the software will achieve accuracy, range of detection, and development time. Given the spectrometer is an advanced instrument, the magnitude of data output is considerable and therefore care is required when operating from a microcontroller. Microcontrollers, or systems with low processing power, are sensitive to overflow when multiple operations need to be performed on large amounts of data. Additionally, memory is limited on a microcontroller thus implying a good management of memory is necessary for

system stability. The software must therefore be thoroughly tested and cleverly written without compromising the requirement of development time.

For that reason, the software team must find a balance between development time and coding that is error free to guarantee stability of the machine. Considering that a wide range of material detection is required, stability becomes more sensitive since this further increases the extent of data and operations required. The coherency of the software is imperative to allow a max CPU usage condition without any stability issues since certain materials may require complex analysis. Moreover, the software must be tailored to minimize the power usage of the machine. Not only the actioning of the delivery system and lightning must be optimized, but the logic for material detection must be efficient to avoid lengthy processing time.

In addition to the caution required by the software, close attention is also vital when designing the microcontroller. The MCU board will be a complex component, as it must contain a voltage reference (DC to DC converter) with a current rating adequate for powering two spectrometers, and enough CPU pins to control four relays and data communication with the spectrometer. Although the MCU's score in the House of Quality was notably lower than other components previously reviewed, it still can substantially increase cost and development time if not executed correctly. Care must be taken when designing the PCB and its components, since errors in the final design will require a second manufacturing attempt, doubling the originally proposed cost. To avoid the risk of hindering the essential requirements of cost and development time, the team must allocate sufficient time and resources to effectively manufacture the board in a single attempt.

On the other hand, the remaining two components in the House of Quality analysis have a weak relationship with the essential requirements. The power source of the system and the IR sensors required for the delivery mechanism must be adequate for the machine, but do not require a lengthy design process. Moreover, the power requirements have a high margin of error as additional batteries can be connected in parallel should unanticipated drain occur. Due to the size of solar panels, the machine is restricted to a single 100W charging panel since more powerful units exceed the desired dimensions for the CAWSS. The power system therefore does not command as much attention as other components. Last, the IR sensors used for the conveyor belt are inexpensive and have sufficient range, and replacing the units if the sensors are not working in order will not interfere with the essential requirements.

2.8 - Initial Block Diagrams

The following block diagrams describe the routines, processes, and general functioning of our design. This first diagram in particular offers a high-level view of all device systems, and highlights which systems each group member will be responsible for over the course of our design process.

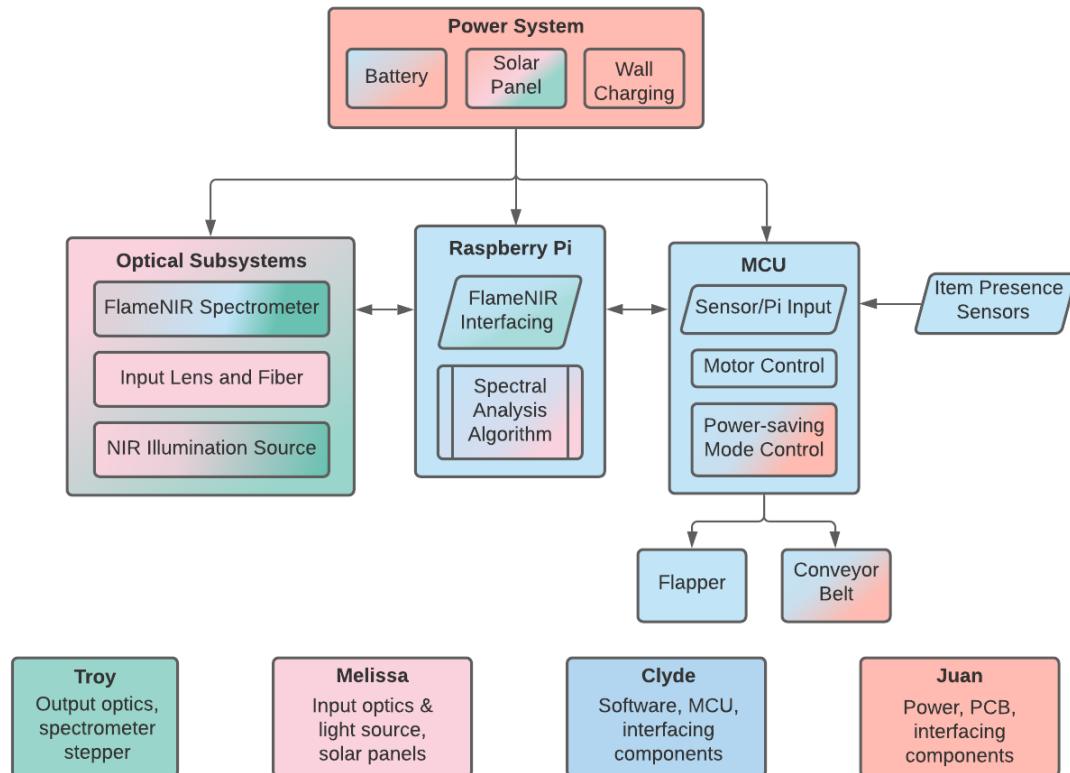

Figure 1. Generalized Flowchart for CAWSS Systems & Processes

This second diagram describes the high-level sequence of actions our software will direct our device to perform. The tasks in this diagram are not color-coded by group members, but rather purely to show whether they are the responsibility of the MCU's software architecture, or our Raspberry Pi's. This distinction is explored in great detail in further sections of the paper, especially section 5.8.

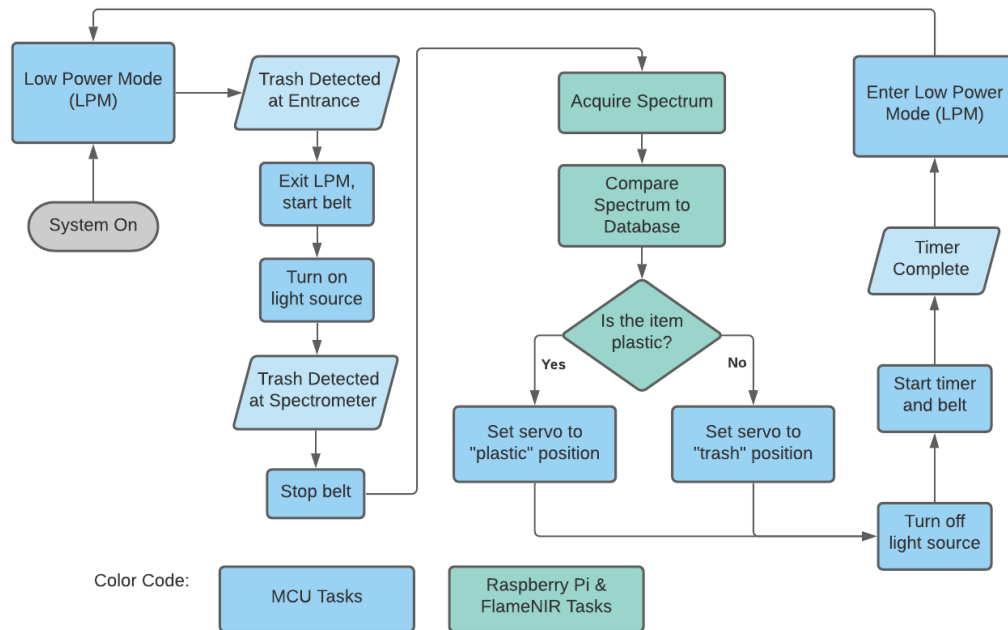

Figure 2. High-Level CAWSS Software Flowchart.

3 - Research Related to Project Definition

3.1 - Existing Similar Projects and Products

The concept of sorting waste via spectral analysis is hardly novel, and has been presented in several geometries. This project is centered around discerning plastic recyclables from other types of waste. This requires the use of the near- and mid- infrared bands of the spectrum, as most plastics display their main absorption peaks in this range. The “exotic” near infrared spectrum (NIR) is the most commonly applied because of the well-defined reflection features displayed on spectrographic charts. CAWSS allows waste sorting to be performed in a semi-portable fashion that allows its application in both commercial and public spaces.

3.1.1 - Voluntary Non-Automated Multi Stream Can Solutions

The current consumer-to-bin product that is seen in everyday application is the multi stream trash can. These can appear as simple “recycling vs waste” cans, or can have multiple openings (“paper,” “plastic,” and “trash” being a few common options). Conscientious consumers take the time to attempt to sort their waste into the correct openings, while less mindful users simply toss all of their trash into one bin. This frequently results in three tandem issues: recyclable bins end up with incorrectly sorted recyclables, recyclable items simply end up in the garbage, and non-recyclables frequently end up misplaced in recyclable

bins. The Echelon Collection™ 75 Gallon Three Stream Recycling Receptacle manufactured by Ex-Cell Kaiser is pictured in figure 3. It can be



Figure 3. A standard multi stream trash can. Reproduced with permission from Ex-Cell Kaiser.

noted that basically no technology is required for the application of this common can setup, which costs upwards of \$1500.

3.1.2 - Handheld Spectrometers for Plastic Detection

CAWSS's portability expectations draw inspiration from other on-site spectrographic solutions. Portable, hand-held NIR spectrometers are widely available on the market as plastic waste sorting solutions. These hand-held units still require human analysis and sorting, and are mostly advertised for home use. This technology reduces the error in plastic identification, but still offers no solution to human operating cost.

Portable spectrometer design requires low power consumption, user interface, and compact design. The CAWSS has similar requirements - the CAWSS power consumption must be low enough to be powered by a practical amount of on-unit solar panels, and space constraints call for a compact design. The self-lighting nature of handheld spectrometers offers a tempting alternative to our top-down lighting design for both efficiency of collection and ease of design. User interface, although not required, sets a worthy stretch goal for the CAWSS design. Instillation of handheld spectrometers into specialized multi-stream waste bins has been contemplated, but appears to have yet to come to fruition



Figure 4. The ThermoFisher microPHAZIR PC Analyzer (Permission Pending)

One example of a handheld NIR spectrometer used in the field is the ThermoFisher microPHAZIR™ PC Analyzer (figure 4). This product was created with efficient assisted hand-sorting in mind. This design weighs a total of 2.75 lbs - portable, and easy for an average person to hold. A tungsten light bulb is utilized for the light source, similar to the CAWSS design. Tungsten bulbs can output the required spectrum while maintaining compact geometry and power requirements. The microPHAZIR™ features a splash proof housing. Similar housing would be a reasonable consideration for CAWSS: it's not uncommon for people to discard semi-full beverages, which would fry the CAWSS's electrical system if left unprotected. This would also be considered a stretch goal for this project.



Figure 5. the trinamiX handheld plastic sorting solution (Permission Pending)

A more sophisticated solution is the trinamiX handheld NIR spectrometer. The trinamiX functions by illuminating the sample from light sources placed around the detector (see figure 5). Results are then sent to a smartphone app via cloud for utilization by the end user. This remote-data feature combined with its small size and 6,000 measurement battery life fulfill its portability requirements.

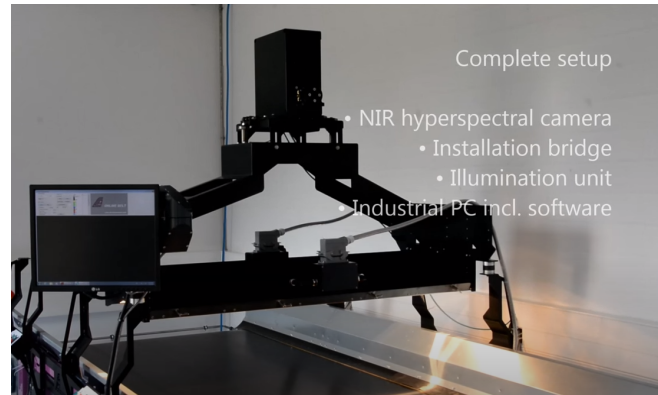

Figure 6. LLA KUSTA camera setup. Courtesy of LLA Instruments, Berlin

3.1.3 - Industrial Spectrometry Waste Sorting

Industrial applications of NIR for recyclable sorting have been utilized for some time in modern processing facilities. These join applications of mechanical separation such as rotational separation via holes in a drum and air jet separation, magnetic separation of appropriate metal, and x-ray differentiation.

Commercially sold NIR linescan cameras are commonplace in the industrial waste world due to their ability to process a high volume of waste all at one time. LLA's KUSTAx.xMSI series of cameras is an excellent example of this (figure 5 - includes pc software and mounting bridge). The wide line scan FOV allows all passing waste to be seen by the system as long as the conveyor belt speed does not pass 3 m/s. This speed is dictated by the speed of the imaging system - an InGaAs array with an imaging speed of 795 frames per second. The three different iterations of the product offer sensitivities in the 0.95-1.7 μm , 1.32-1.9 μm , and 1.62-2.19 μm ranges, respectively. Software that displays color-coded identification of all passing waste is displayed via the accompanying computer. Similar software will be created for a CAWSS application if time permits.

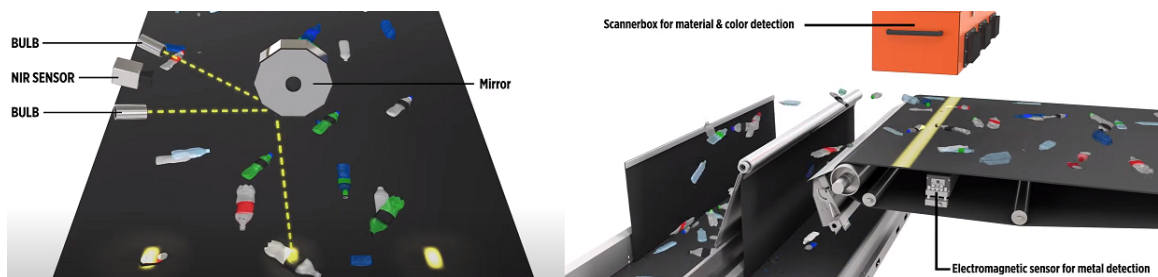

Figure 7. Tomra Automatic Waste Sorting System (Permission Pending)

Tomra's line scan camera is an alternative linescan product whose internals can be seen in figure 7. It utilizes a "barcode" method of providing light for the linescan system in an evenly distributed manner through its FLYING BEAM® technology. This is accomplished by illuminating a rotating mirror with light, which is then projected across the line. This is then returned to the NIR sensor from the same mirror facet after being reflected from the target. Tomra's camera specs and sorting speed were not available on its website, most likely because the entire sorting machine is sold as a packaged product.

3.1.4 - Previous Waste Sorting Senior Design Applications

Waste sorting has been tackled in a handful of Senior Design projects in the United States. None, however, offer a comprehensive system that both identifies and automatically sorts incoming objects. Each offers an element which the CAWSS team could potentially utilize in the design of the project.

A team at UC Davis created a Smart Bin. This bin features a compartment in which a camera was mounted. Machine vision was used to train an AI, which in turn is used to identify the type of waste present. The user is required to place the waste into the correct container after identification is complete. Machine vision isn't required for the CAWSS plastic functionality, but would prove useful if further sorting functionality were required. A similar product that was automated with a pulley system and a trapdoor was created by Rutgers University students.

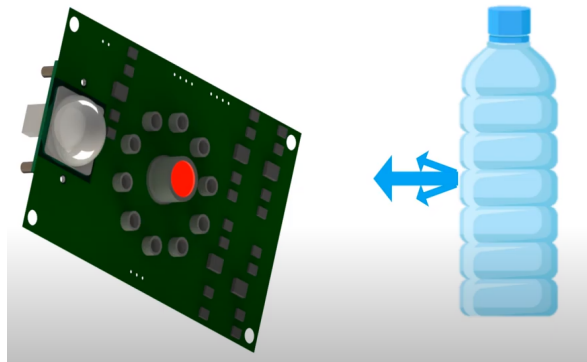

Figure 8. BioRhythm PCB spectrometer design. (Permission Pending)

BioRhythm was created by students at the University of Colorado at Boulder. The concept of this creation was to place an item under a spectrometer, and then place the item in the correct recycling channel as indicated by LED lightstrips. The spectrometer's design is of particular interest - the IR lightsource was placed in the middle of a ring on sensors (see figure 8). All were placed directly on top of a PCB, offering a compact design and low power

consumption. This design could be drawn from for inspiration for CAWSS, as it requires both compactness and low power consumption.

Mechanical engineering students at University of Mississippi created the Earth Saver - a purely mechanical waste sorting system. The system featured a plastic brush through which glass samples would fall, leaving lighter materials sitting on top. Magnetic components were then sorted out via a magnetic drum, and from there plastic and aluminum were sorted by size and shape. This offers the CAWSS team many ideas for extrapolation on the current design - future iterations could feature metal and glass sorting without requiring further, expensive spectrometer additions.

3.2 - Relevant Technologies

The technologies applied to the CAWSS project must be thoroughly investigated before components can be investigated and selected. This section covers all main components that will be used in CAWSS. The purpose of this is to develop a deeper understanding of the technologies available and the theories associated with their functioning and development.

3.2.1 - Optical Fibers

This subsection will briefly explain the mechanisms through which optical fibers function so that later the optimal fiber may be chosen. The CAWSS requires a fiber-optic cable to be utilized for delivery to the spectrometer. A deeper discussion of the currently available fiber-optic technologies will be made in an effort to make an informed fiber selection.

Fiber Basics

Optical fibers are waveguides that are used to transmit information via modulated light signals. They function by enclosing the light signal inside of a multi-layered circular tube. This circumnavigates difficulties presented by the open configuration and alignment requirements presented by free space optics.

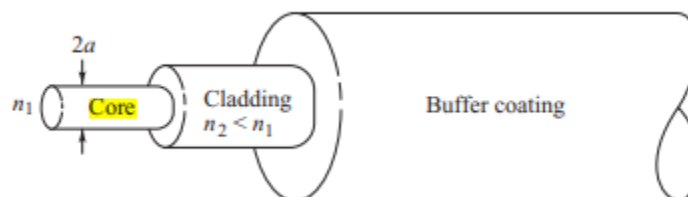

Figure 9. Anatomy of an optical fiber. Reproduced with permission from Optical Fiber Communications, McGraw-Hill, 4th edition by Gerd Keiser

The general configuration of the fiber consists of a core, a cladding, and a protective coating (figure 9). The cladding is always a higher refractive index than the core, and serves to act as a mirror to the traveling light wave via total internal reflection. The fiber's core is generally made of silicon dioxide (SiO_2) with a cladding made of glass. The properties of a fiber can be manipulated via "doping," a method of purposely contaminating the core of a fiber in a controlled manner in order to manipulate the core's index profile. Two main index profiles are used in the field today: step-index and graded-index. Index profiles, combined with the choice between propagating a single mode or propagating multiple modes, determine both price and performance of an optical fiber.

Single mode Vs Multimode Propagation

Single mode fibers are well suited for long-distance communications and data transmission as they experience less dispersion. Single-mode operation is maintained by their $>10 \mu\text{m}$ core size. This requires them to only accept light from normal incidence, which requires a laser source to fulfill - and also calls for precise, expensive manufacturing. Multimode fibers are bandwidth limited over a long distance by intermodal dispersion and are therefore only useful for short-distance transmission. Multimode fiber can send much more information over short distances, and can have such large cores ($50 \mu\text{m}<$) that even LED emissions are acceptable as light sources.

Index Profiles

After single mode or multimode transmission is taken into consideration, the profile of the doping must be chosen (see figure 10). Step-index fibers have a simple, sharp core-doping transition that is cheap to manufacture. Incoming rays that are at a wide angle of incidence to the surface normal become higher-order modes while in the fiber. Every mode in a step-index fiber travels in a zig-zag pattern, with frequency of pattern repetition increasing with mode number. This results in the occurrence of a high amount of intermodal dispersion. The incident higher-order modes occasionally aren't fully confined by the step-index profile, resulting in "leaky modes" that cause attenuation by escaping readily. These two factors cause the attenuation and dispersion of step-index fiber to be significant over long distances. This makes the use of step-index fiber impractical for anything other than single-mode applications or low budget short-distance multimode projects.

Graded-index profiles go from a higher refractive index in the center of the fiber to a lower refractive index towards the edges. This serves to reduce the amount of dispersion caused by interfering modes - this makes the use of this product pointless for single-mode applications, which have no intermodal dispersion. The numerical aperture characteristics of a graded-index fiber are radially dependent, and less light is generally collected by this index profile.

Graded-index fibers are much more expensive than step-index fibers, but offer a greatly increased distance-bandwidth ratio. The parabolic shape of the index profile serves to bend the incoming electromagnetic waves back into the fiber, forcing them to be better contained than the leaky step-index profile. This causes more power to be contained over a longer distance, allowing multimode propagation to be applied to longer-distance applications.

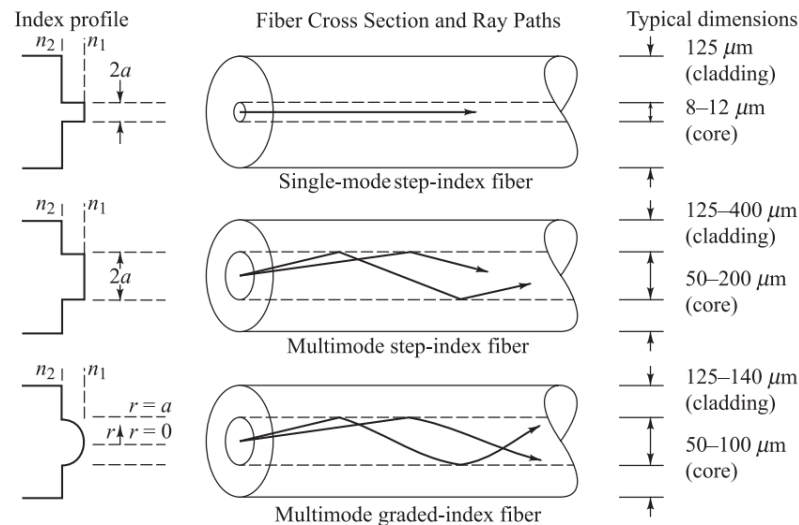

Figure 10. Diagram of step-index and graded-index fiber profiles. Reproduced with permission from Optical Fiber Communications, McGraw-Hill, 4th edition by Gerd Keiser

3.2.2 - Spectrometers

The heart of CAWSS design revolves around use of a spectrometer in order to differentiate recyclables from other waste materials. A couple spectrometer options are available for CAWSS implementation. A discussion of spectrometer basics is made here in an effort to aid spectrometer selection.

Types of Spectrometers

Spectrometers are a popular tool for differentiating substances based on the spectrums released after excitation. These can come in the form of mass spectrometers, nuclear magnetic resonance spectrometers, or optical spectrometers. The spectrometer utilized in CAWSS is an optical spectrometer operating in the near infrared region. Optical spectrometers can be found for every optical wavelength, the most popular spectrums being infrared, x-ray, and ultraviolet. Spectrometer applications can range from manufacturing to space exploration, and even to waste management.

Spectrometer Layout

The most basic spectrometer layout traditionally consists of light inputted into the system through an input slit or fiber. This input slit can range from 15 to 100 μm , and dictates both the resolution of the system and the amount of light collected. Usually a choice between the two must be made - a smaller slit corresponds to higher resolution, but collects less light. This corresponds to the Rayleigh Criterion for a single slit, defined by $\sin\theta_R = \frac{\lambda}{d}$ where λ is the center wavelength and d is the slit diameter. This can be translated to resolution in terms of pixels through a slightly different calculation (provided by Ocean Insight's Flame NIR documentation) - $\frac{\text{spectrometer range} * \text{pixel resolution of detector}}{\text{number of pixels}}$. The light then passes through a collimating lens so that all rays are collected and traveling in the same direction. The collimated beam then is incident upon a diffraction grating to separate out the individual wavelengths, which is then focused onto a detector array for analysis (see figure 9). This design is altered as needed for compactness, functionality, and accuracy.

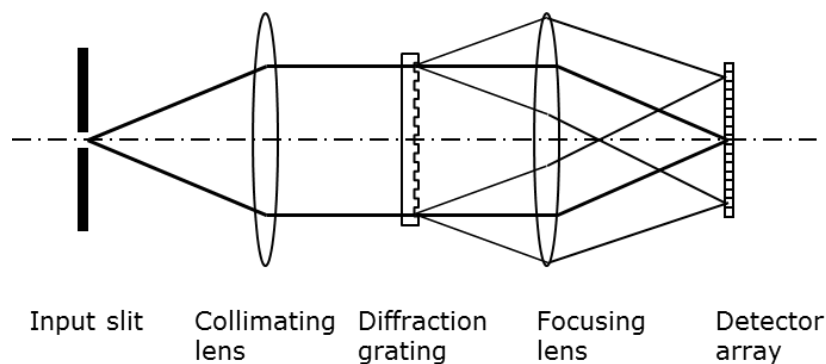

Figure 11. Traditional Spectrometer Design. Reproduced with permission from Ibsen Photonics.

3.2.3 - Sensor Technology

Sensors are expected to be implemented in CAWSS in order to acquire size information based on speed of movement and time present in the sensor path. This information will be used to determine at what points the conveyor belt should be stopped and the spectrum sampled. An understanding of passive and active sensor differences and application is primarily being sought. Semiconductor photodiodes lie at the heart of light sensor technology. Sensor configurations include passive sensors and self-emitting active sensors (see figure 10). Both of these configurations have situational applications in which they excel.

Passive Sensors

Passive sensors rely on incoming light from an external source. Common passive sensor configurations include those that sense light emitted from a

black body (passive IR sensing) or receipt of light from stimulated or spontaneous output such as a laser or LED. The non-compact configuration of passive sensors can have both geometric and financial repercussions. Natural light sources such as the sun frequently require efficient photodiodes. A light source that is chosen by the engineer requires a source with adequate strength and proper positioning with reference to the desired photodiode. A self-provided light source can be used with a reflectance configuration such as that seen in figure 10, or can be used to detect a “lack” of the presence of light. The latter situation is useful with a laser to sensor configuration, such as the path of a laser being blocked by trash traversing a conveyer belt. Common commercially available passive sensors have much more potential than active sensors when long-range sensing is required in civilian applications.

Active Sensors

Active sensors are based on the concept of self-contained excitation that is placed alongside or close to the sensor. These self-contained units can cost significantly less than a custom passive sensor system, and are widely available with microcontroller unit interfaces. All active sensors are based on reflectance. One of the most commonly used sensors is the IR sensor module, although other spectral ranges are available for a minimal price increase. Many commercially available active sensors use LEDs as light sources, rendering them practical for only short range sensing (many times less than a foot) due to the incoherence of the light source. Less common active sensors include range finders, which offer highly accurate long-distance measurements.

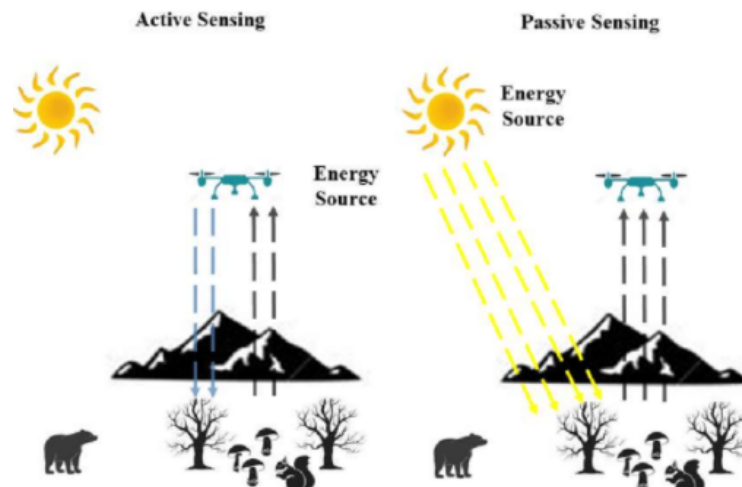

Figure 12. Active vs passive sensing. (Permission Pending)

3.2.4 - Infrared Light Sources

Infrared light is most easily produced through blackbody radiation. Blackbody radiation is light that is emitted from heated bodies. Every wavelength in the electromagnetic spectrum can be emitted in this manner, with each temperature

providing a different peak wavelength (see figure 13). The sun and the human body both emit infrared simply from their own intrinsic temperature. These examples illustrate the simple fact that the hotter the body, the more visible light it emits. The most easily accessible infrared sources are gas-based blackbody lights like halogen and incandescent bulbs. These offer broadband spectrums without any specifically highlighted wavelength. Incandescent bulbs output a particularly desirable spectrum without any significant peaks. Halogen bulbs have a less evenly distributed output that has a bulbous peak centered towards the left of the spectrum that can be attributed to the gas itself. The halogen's skewed distribution can be somewhat overcome by strong enough emission, but the skew still must be taken into account in the final graph. Infrared lasers and LEDs working off of semiconductor principals are actively used and widely available to the average consumer. These offer a far narrower spectrum, which - in the case of the laser - can be confined to only a few nanometers.

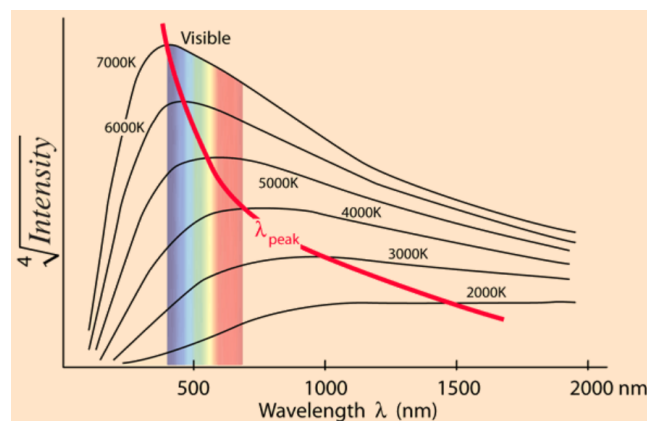

Figure 13. Visual representation of Wein's Law. Reproduced with permission from Rod Nave.

The quality of any light source can be determined by luminous efficiency as given in the equation $\eta(\text{lm/W}) = \Phi_V(\text{lm})/P(\text{W})$. This determination proves vital when selecting an appropriate light source - the household infrared sources available have an average fixed luminous efficiency (15 lm/W and 18 lm/W for household tungsten incandescent and halogen sources, respectively). Luminous efficiency combined with desired luminous output allows the required wattage to be calculated and applied. This equation, when combined with Wein's Law, proved vital for CAWSS component selection.

3.2.5 - Light Focusing Elements

The basic concepts of physical optics are lengthy and have developed over many centuries. Therefore, these will not be covered in this section. Instead, the types of light focusing elements that might be applied to CAWSS will be discussed. This section is different from component selection in that a discussion of why certain types of optical elements can be applied will be made - the component selection itself will compare pricing and functionality.

Concave Mirrors

Concave mirrors are considered to be focusing elements. This can be easily explained with a simple ray diagram (see figure 12). All rays originating from an object a long distance away from the mirror cross the axis at the same focal point. This makes mirrors a practical way to guide light into the other optical elements of the system. This method would eliminate chromatic aberration that can be caused by refractive elements - however, this is of little consideration to the project as visual imaging does not occur. The focused ray bundle might not be as tight as might otherwise be achieved by a lens, but would also cost significantly less than lenses available for these wavelengths.

Any mirror selected would have to be able to handle the almost 700 nm of bandwidth required for full spectrometer functionality. Multiple mirror types are available, and may be selected on shape, functionality, material, and cost. Appropriate materials for the CAWSS's include dielectric materials (350 nm to 1600 nm), silver or aluminum (450 nm to 20 μm), and gold (800 nm to 20 μm). Reflectances for these vary from 90% to 97% - some of these reflectances are better suited to building laser oscillators or other devices in which some amount of emission is desired. Shapes available for purchase include circular flat, circular square, elliptical, concave, and parabolic mirrors.

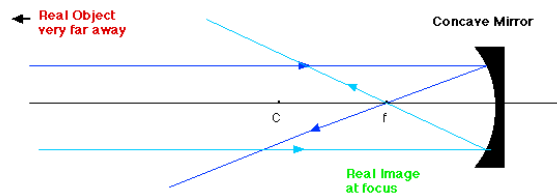

Figure 14. Simple ray trace of a concave mirror. Reproduced with permission from John Jerrett.

Concave/Focusing Free Space Lenses

Free space lenses offer greater light-catching abilities than mirrors. The correct choice of lens or lens pairings allows light to be refracted tightly to a spot behind the lens. Incoming light doesn't run the risk of randomly bouncing to a different location, but instead is more likely to be collected as desired. Chromatic Aberration is always present in refracting optics, but as previously noted would not make a difference to our work. The biggest downside to using a free space lens is the cost - some lenses can cost upwards of \$400. Lenses that refract the required wavelengths include magnesium fluoride (200 nm - 6 μm), calcium fluoride (180 nm - 8 μm), and fused silica (185 nm - 1m), and N-BK7 glass (350 nm - 2 μm). Each comes in a limited variety of sizes, none surpassing 75 mm. A note must be made about fused silica: the common variety of fused silica is UV grade, and has enough OH to create low transmission in a few key places in its transmission spectrum. Special IR grade fused silica must be purchased for the high transmission desired for CAWSS.

Several lens shapes are available, and should be chosen for the configuration at hand. The chromatic aberration introduced by the lens elements could be counteracted by an achromatic doublet (figure 14 a), if desired - a combination of a negative and a positive lens. Cylindrical lenses can be used to “shape” light via changing the magnitude of the light along one axis (figure 14 b). Convex lenses create a virtual image, and concave lenses focus light to a point behind the lens (figure 14 c). The ideal choice for CAWSS is a convex lens - no correction or shaping needs to be done, only focusing (figure 14 d). Matching the lens’s numerical aperture to that of the fiber assures that light is not lost during the transfer between the two.

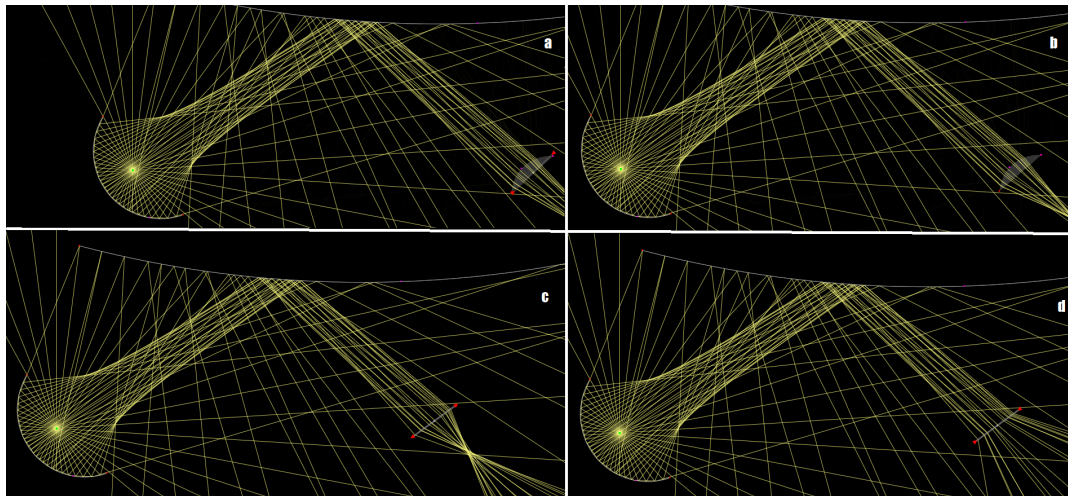

Figure 15. Ray traces associated with a) an achromatic doublet, b) a cylindrical lens, c) a convex lens, d) a concave lens.

3.2.6 - Solar Panels

Solar panels will be powering CAWSS so that total or near-total green efficiency can be achieved. Market availability and solar panel function dictate the selection of solar panels in this project. This section details both, in addition to the extra needed components for proper solar panel integration.

Functionality and Availability

Solar panels are the most affordable way for individuals to generate clean energy. Solar panels are constructed from photovoltaic cells, which are essentially very large photodiodes. Solar technology creates power from solar radiation. The current induced by incident light is collected from the solar cell via electrodes for utilization by the desired electrical system (see figure 13).

Solar arrays range in size from very small (small enough to fit on a dashboard bobblehead) to very large (large enough to be practical for use in a power plant). Size and efficiency of solar arrays are both factors that influence the amount of

power generated by a panel. The largest commercially available solar panel is currently 500 watts, although the most easily acquired panels generally do not exceed 300 watts.

Solar arrays generally require extra technology for them to function properly. The dependence of solar technology on the availability of sunlight makes its supplied power unreliable during the day and unusable at night. This problem is currently circumnavigated by storing solar power in batteries for later use. The power output by solar panels is DC, and requires AC conversion before use with most electrical equipment. Conversion in solar systems is accomplished with the use of an inverter, and is a standard component of any solar system. Solar panels don't always put out the same amount of voltage. Semiconductors behave differently under different conditions - variables such as temperature can impact the value of the output voltage. Voltage regulators are used to provide consistent voltage to the system so that the battery and other connected components function correctly.

The vast amount of visible and infrared radiation incoming from the sun can be harvested and stored via photovoltaic cells, also known as solar panels. Solar panels are sheets of semiconductor material that make up a large scale PN junction. A PN junction is the basic principle by which diodes and transistors work, where two layers of semiconductor material with different free electron densities interact with each other. In the junction, free electrons will drift to the neighboring section of the semiconductor layer with smaller free electron density; this process will carry on until such a region can no longer accept free electrons. This area where all electron-hole pairs are filled, called the depletion region, allows for the PN junction to develop a potential difference between layers given electron drift gives rise to materials turning positively and negatively charged. The result is a material that allows current to flow through the positive-negative orientation of the PN junction while opposing current flowing through the opposite direction.

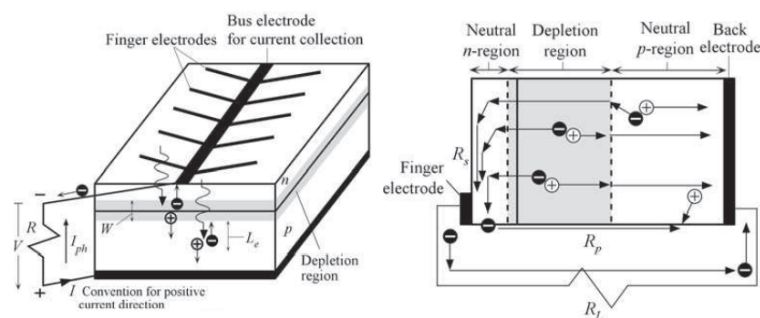

Figure 16. Function of a photovoltaic cell. Reproduced with permission from Optoelectronics and Photonics, 2nd Ed by Safa Kasap.

Solar panels utilize the PN junction by allowing solar radiation to further scramble free electrons past the depletion region, ultimately enlarging it. This widening of the depletion region further increases the potential difference between the semiconductor layers, and usable voltage can therefore be extracted from the solar panel. By connecting both top and bottom ends of the semiconductor layers, the circuit closes to act as a voltage source. Each one of these loops is called a cell, and solar panels are constructed using an array of cells in series connected in parallel to other arrays. The series connection increases current while the parallel interconnection improves capacity, explaining why solar panels are found in multiple shapes depending on the application. A typical cell is rated from 0.45V to 0.55V, and therefore solar panels can contain as few as 36 cells to over 144 to achieve a desired output voltage.

Moving on, the efficiency of solar panels is negatively affected by hot ambient temperatures and the structure of the silicon employed. Polycrystalline solar panels are cheaper but less efficient than monocrystalline panels, due to electron drift being restricted when multiple crystalline structures are in place of one.

Last, to power a load or charge a battery via a solar panel, a solar panel regulator is typically employed. Given the panel will output current proportional to the intensity of the radiation, a driver is necessary to limit current in certain scenarios such as powering a load rated for a lower voltage than the panel. Additionally, solar regulators have the capacity to charge batteries automatically. These units detect the battery's current charge and type to replenish the battery with the appropriate current cycle. Charging a battery without a driver can overheat or damage the battery even if both elements are rated for the same voltage.

3.2.7 - Processors

There are many different types of processing solutions available for embedded projects like ours. Three broad types that include many commonly-used solutions are Field-Programmable Gate Arrays (FPGAs), Single-Board Computers (SBCs), and the ubiquitous microcontroller (MCU).

Field-Programmable Gate Array (FPGA)

FPGAs are very different from other processing solutions. As their name suggests, they are essentially an array of logic gates that can be reconfigured as required through the use of a Hardware Description Language (HDL) like Verilog or VHDL. In other words, an FPGA allows developers to optimize a design far more than with other processors, at a hardware level. These devices may be unnecessary and costly for many embedded projects, but grants far greater

control to developers who need to optimize all parts of their design. Nonetheless, for the vast majority of embedded systems, this level of granular control is simply unnecessary.

Single-Board Computer (SBC)

Single-Board Computers have become increasingly popular in embedded applications over the years. Among a growing and diverse field of options that only grows in processing power while remaining small and low cost, the Raspberry Pi line of SBCs stands out as a pioneer, the first to truly make more sophisticated computing available in a small, low-cost form factor to embedded and DIY developers. SBCs are particularly useful when more sophisticated interfaces or server functionality is required that a microcontroller cannot support, or simply for the additional processing power required for tasks like machine learning. In theory, they can also perform many of a microcontroller's functions, but may include fewer features specific to embedded applications (such as timers or hardware interrupts) and must deal with the additional load of running a fully-fledged operating system. In practice, this makes them less ideal for tasks like the generation of PWM output for motors, and makes them unable to provide some of the stricter performance guarantees that an MCU can.

Microcontroller (MCU)

Microcontrollers have been an essential part of embedded electronic systems for decades. These integrated circuits contain one or more processing cores, as well as the necessary memory and input/output interfaces required to use these devices. They can be packaged with a wide variety of peripherals and features useful for embedded applications, such as hardware timers and interrupts. A microcontroller tends to be relatively simple, often omitting components for networking or graphical processing that a more modern, complex system on a chip may include.

This simplicity has led to MCUs becoming extremely power-efficient; lower-powered devices exist with power consumption in the microwatt or single-digit milliwatt range. Even most general-purpose MCUs have the ability to enter power-saving modes while waiting for an interrupt event, temporarily disabling peripherals and the CPU clock without any loss of functionality. Despite this focus on efficiency, an MCU provides ample processing power for many embedded applications, such as engine control systems, medical devices, and everyday appliances. The dedicated peripherals that these devices often include are not found on most general-purpose computing platforms today, making an MCU the de facto choice for applications that require reliability above all else, even if it comes at the cost of speed.

3.2.8 - Batteries

The absorbed glass-mat battery was developed during the 1970's and was first used as an extended battery power and extended battery life option for power backup systems. As the tech became less expensive, it began to make its way to more common applications like vehicles and personal use. The AGM batteries have a considerably larger capacity compared to traditional flooded batteries due to the electrolyte being contained in fiber-glass structures, which allows a more efficient power transfer to the lead plates when the chemical reaction takes place. This principle also facilitates the recharging of the battery, requiring less voltage and heat, thus aiding in the longevity of the instrument. Additionally, AGM batteries have a sealed design which is also found in other types of batteries. This design prevents H₂O in the battery from venting during normal chemical reaction, which decreases the performance of the battery with time. Sealed batteries trap these vapors and reroute them via a valve system to prolong the batteries effective lifespan.

For large battery powered systems or those with mechanical parts, AGM batteries will not only allow more power extraction per cycle, but also withstand higher charging currents in the event the battery must be recharged at full speed. The downside of AGM batteries, besides cost, is their sensitivity to overheating which can destroy the battery in a single event. This condition is most likely to be encountered when charging and a reliable battery charger must be used.

3.3 - Strategic Components and Parts Selection

A wide range of components were considered for every aspect of parts selection. This section serves as a record of parts considered, and why certain parts were chosen over others. The parts ultimately chosen are summarized in a table in section 3.5 of this section.

3.3.1 - Fiber Selection

The fiber in our design serves to collect light from a specific location in our device and deliver it to the spectrometer for analysis. This requires a fiber that considers both the physical limitations of the system and the requirements for near infrared light transmission. The physical limitations of the project call for a fiber with the correct connectors for the system, a fiber long enough to transport incoming light to the final location of the spectrometer (the expected amount needed is between 1 and 5 meters), and a large enough numerical aperture to collect a sufficient amount of light for analysis. Minimal hydroxyl concentrations are ideal for infrared transparency, making this a desirable characteristic for the fiber used in CAWSS. The small length of fiber required for this project made dispersion only a small part of component consideration. Fiber cost and work required for fiber preparation was also considered.

Thorlabs GIF625

This graded-index multimode fiber offers a numerical aperture of 0.275 and a 65 um core. A 50 um core fiber was also available, but offered a numerical aperture of only 0.2 and therefore was not considered. This fiber costs \$1.33 per meter, giving the appearance of a cheap light transportation solution. This is misleading, as nearly all the required components for interface and protection are missing. Unfortunately no pre-assembled patch cables (a completely assembled fiber setup with a connector on each side) were available for graded-index fiber from Thorlabs.

The fiber itself is not reinforced, and would require the purchase of additional protective coating (known as a “jacket”) to provide enough sturdiness to the fiber for flexibility purposes. Thorlabs GIF625C doesn’t come with connectors pre-attached, which then requires purchase and manual installation. The spectrometer in this project utilizes standard SMA 905 connectors, and cost around \$11.35. The fiber’s supported wavelengths are between 800-1600 nanometers during laser transmission, but see reduced bandwidth at broadband emission operation. No special adjustments were noted for hydroxyl (OH) adjustments. The time required to implement this fiber would most likely not be worth the reduction in attenuation and dispersion since it will only be implemented for a short distance. Alternative graded-index options included a multimode patch cable available for a hefty \$132 for only 1 meter of fiber - not nearly long enough for our purposes, and not worth the price increase.

Thorlabs FG200UEA

The FG200UEA is a pre-assembled step-index SMA to SMA patch cable. The cable’s refractive index profile allows light to be more easily collected by the fiber, and has a numerical aperture of 0.22. This numerical aperture is ideal, as it is matched to the spectrometer’s numerical aperture. A core size of 200 um allows the maximum amount of incoming light to be transported by the fiber. The core size to spectrometer ratio is of little consequence, as any excess light attempting to enter the spectrometer is simply blocked by the entrance slit. The fiber is doped for low OH, and is therefore optimized for infrared transmission. The fiber is covered in a jacket, and is therefore protected from bends and other external stresses. This double-connector configuration is ideal for connection with a fiber-mounted lens for the focusing of incoming light. This fiber is perfect for CAWSS implementation - however, the cost is quite significant at \$125.53 for 5 meters. This fiber was ultimately purchased for the project. A comparison table of all fibers can be seen in table 3.

Fiber Type	Numerical Aperture	Core Size	Cost	Assembly needed?
Thorlabs GIF625C	0.275	65 um	\$30	Yes
Thorlabs GIF50C	0.2	50 um	\$30	Yes
FG200UEA	0.22	200 um	\$125.53	No

Table 3. Comparison of considered fibers

3.3.2 - Spectrometer Selection

The spectrometer implemented by the CAWSS system had to be selected based on ease of implementation, wavelength range, and cost. Power requirements for the system were designed around the use of the spectrometer, and therefore power was not a limitation considered during spectrometer selection. The wavelength range required to characterize plastics in a manner similar to commercial systems is between 980 and 2100 nanometers. Spectrometers with that wide of a range are very expensive and hard to acquire, and therefore the 980 to 1600 nanometer band was chosen for inspection. Peaks for all common plastic types exist in this range, and therefore made this band ideal for our project.

Two different Ocean Insight spectrometers were considered, along with a self-built monochromator system. The two spectrometers were ultimately loaned to us by UCF CREOL and Ocean Insight, respectively. One of our current stretch goals is to implement both spectrometers in tandem.

Self-Built Spectrometer

The first spectrometer considered for our project was a self-built monochromator. The concept was inspired by a “spectrometer” (later we found this was actually a monochromator) designed and built by Dr. Yuan Cao.

This spectrometer was apparently built for \$500 - upon further research, we came to realize that the price of the lenses used was conveniently left out of the cost considerations in the article. It was found that the full cost of building such a monochromator would have cost upwards of \$1100. This would have endangered our ability to afford the rest of the project components, and thus presented a huge roadblock. Additionally, the programming and assembly of the monochromator would have been incredibly difficult. It was decided that these points were unrealistic both financially and time-wise.

Ocean Insight NIR256-2.1

The Ocean Insight NIR256 is one of Ocean Insight's legacy products, and was loaned to us by UCF CREOL. This specific spectrometer was unfortunately equipped with the wrong diffraction grating for our purposes, and therefore only offers a wavelength range of 1.2 to 2.1 μm . This range only has one identifiable peak for most plastics. This was determined not to be enough certainty for our application. We decided to keep it as both a backup and a stretch goal option without immediate project implementation.

Ocean Insight Flame NIR

The Ocean Insight Flame NIR is a more recent Ocean Insight product loaned to us by Ocean Insight themselves. This spectrometer has a wavelength range from 960 to 1650 nm - perfect for our application. Its 25 μm slit controls the amount of light allowed into the system, and determines resolution. 25 μm is considered to be a small slit and corresponds with a higher resolution system. When the Rayleigh Criterion is applied, the Flame's 25 μm slit results in a 2.934 degree separation when the wavelength in the center of its detection range, 1280 nm, is considered. The resolution in terms of pixels can be calculated via the equation presented in section 3.2.2, and yields a resolution of a 1.9 nm FWHM. It uses less than 250 mA of current and operates at 5V, making it a highly efficient option for our power budget. Its numerical aperture is a common 0.22. We have chosen this spectrometer specifically for its wavelength range, but the additional specs listed offer nice bonuses. A comparison table of available spectrometer options is presented in table 4.

Spectrometer Type	Wavelength Range	Cost	Assembly needed?
Self-Built	Any desired	\$1100+	Yes
NIR256-2.1	1.2 - 2.1 μm	On loan	No
Flame NIR	960-1650 nm	On loan	No

Table 4. A comparison of spectrometer options.

3.3.3 - Light Source Selection

The light source used to illuminate samples for waste characterization is equally as important to CAWSS function as is the spectrometer. The ideal light source for this project would have a temperature of between 2000 and 3000 Kelvins and would output sufficient light for fiber collection. All light sources were tested out of necessity - testing was required for practicality and illumination requirements although Wien's Law was applied in calculations. These lights were additionally evaluated in the areas of cost, implementation practicality, and power budget.

Our total cost during light source evaluation was roughly \$54. It should also be noted that LEDs were not considered due to their small bandwidth - an impractical number of LEDs would have to be utilized to achieve the broad wavelength band needed for the spectrometer to operate correctly.

FEIT Electric Incandescent 7 Watt Landscape Bulb

The FEIT Incandescent Electric Landscaping bulb was the first light source to be tested by the CAWSS team. A pack of 4 of these bulbs only cost \$6.58, and thus was very economically appealing. 7 watt power consumption makes this bulb extremely power-budget friendly. This bulb's peak light output matches the 3000 K spectrum (refer to figure 11) - this the very upper limit of the CAWSS's desired output spectrum.

The Flame spectrometer's specs didn't list a suggested light source or light source strength. The CAWSS team thought that this source would be a good starting point for understanding what sort of light source was needed. This proved to be incorrect upon testing - despite pointing the fiber directly at the source only a dim spectrum was achieved. This testing episode allowed the CAWSS team to re-evaluate the strength of the light source required for spectral analysis.

The Sun

The sun offers broadband blackbody emission (see figure 14). The light emitted by the sun is incredible even in the trailing infrared region (700 nm to 1 mm wavelengths), and is more than adequate for our application. A plastic reflectance spectrum was even successfully captured by the Flame by one of the CAWSS team, proving its viability.

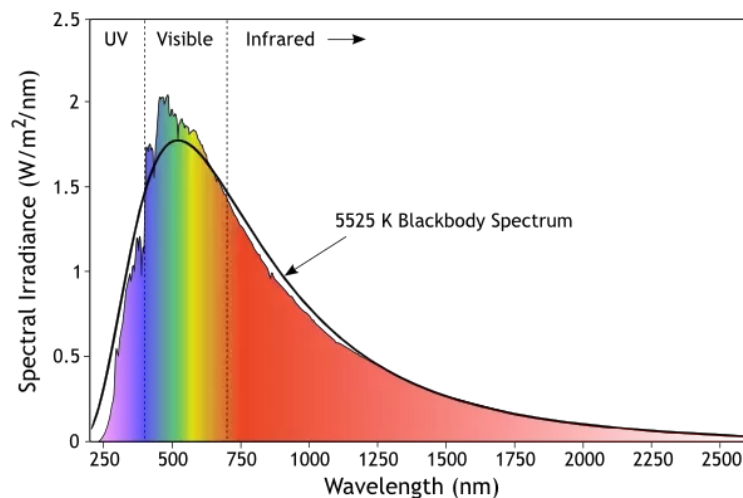

Figure 17. The sun's emission spectrum (permission pending)

The sun doesn't require external power sources or manufacturing, and would be the most "green" option for the CAWSS. An outdoor implementation of CAWSS would require some form of minimal optical setup with which to guide the incoming light; this would hardly be a challenge, as even a handheld magnifying glass can tightly focus the sun's rays. The green benefits of the sun's light are reinforced by the economic benefits - - no one has to pay for sunlight.

The number one detractor for the use of sunlight (and ultimately what kept this choice from being selected) is the practical nature of the sun itself. Clouds reflect infrared radiation, and therefore any ill weather would completely disable the CAWSS. Indoor implementation would also be impractical - light from the outside would have to be channeled into the building and then into the CAWSS. The optical lens system needed to preserve the sunlight's intensity and spectrum for such a long distance might be both costly and difficult to achieve, despite the simplicity of channeling sunlight into the CAWSS itself. The sun always has to be shining and the CAWSS has to always remain outside for proper functionality. This would eliminate any practical application of the device.

Cuda I-150 W Optic Fiber Light Source

The Cuda 150 W Optic Fiber Light Source was briefly borrowed from the Laser Plasma Laboratory at UCF Creol for testing. This lightsource has an adjustable -intensity quartz halogen bulb (luminous efficiency of 24) that can output a maximum of 3600 lumens. Absorption and reflectance spectrums of a UCF ID card were achieved with this device (see figure 18). In theory, these spectrums should be perfect inverses of each other. Since this was a cursory measurement, imperfect lab techniques were used. The UCF ID card has metal components, and the same portion of the card wasn't necessarily sampled. Despite the spectrum imperfections this experiment did serve to prove that the spectrometer/fiber combination would be appropriate for our application. Additionally, the CAWSS team ascertained a practical minimum illumination for the spectrometer's function. It additionally came to light that a flashlight or other light-directing mechanism would improve the amount of light incident upon the sample.

The Cuda was also considered as a light source for implementation. Cuda I-150's cost around \$150 when purchased used, which would far exceed the estimated financial budget for a light source. The Cuda also uses up to 200 W of power - this would literally take up the CAWSS entire power budget, and would make a purely solar product impossible.

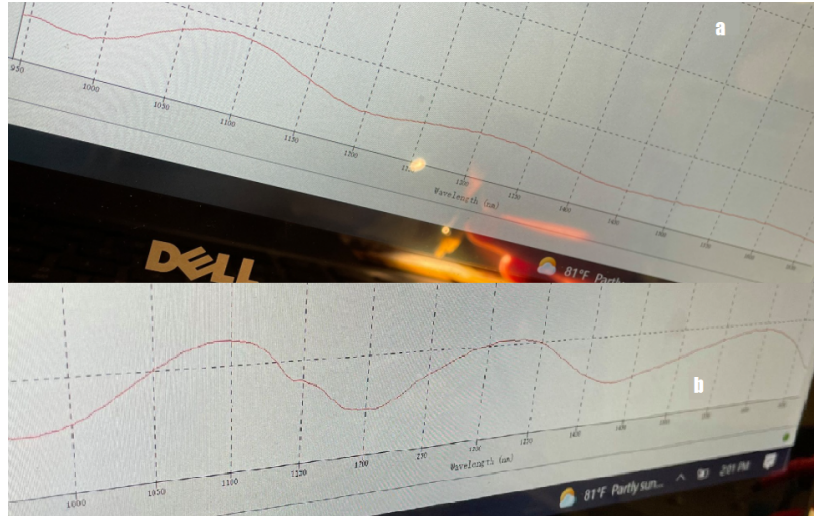

Figure 18. Absorption (a) and reflectance (b) spectrums taken with Cuda I-150 lighting.

HDX Portable Halogen Worklight 250 W

The HDX worklight was originally purchased for its flashlight-like reflective metal backplate. Most metals seem to reflect at least some infrared light. Aluminum is both a cheap way to create mirror-like surfaces and a fantastic reflector of infrared light. The CAWSS team suspects that the metal used in this worklight is some aluminum alloy because of its minimal weight and the minimal cost of the product. Maximum light output requires the metal cage and protective glass to be removed so that reflection or absorption by these materials does not occur. The removal of this cage and the protective glass also allow the wide geometry of the mirror to be fully utilized for the installation of any bulb. Disassembly of this product for such a purpose would require full circuitry removal and backplate drilling. This work light cost \$12.97 and falls under the “housing” portion of our budget. Although not directly housing the entire system, its function was initially structural.

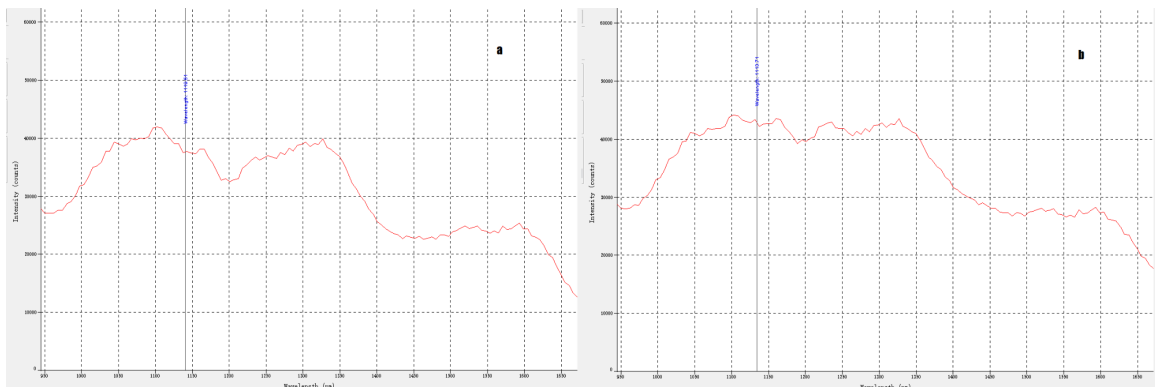

Figure 19. Nearly identical spectrums taken with a 250 W halogen of a) a known PET-G sample and b) a lid identified as a PET plastic.

The worklight itself was tested as a possible light source. This was not its original purpose - however, an output of approximately 4500 lumens was guaranteed to produce a clear spectrum. It features a 250 W 2700 Kelvin bulb - this is towards the upper limit of the desired blackbody source, but is still acceptable for the application. The results of this testing are displayed in figure 15, and clearly show the identification of a known pure PET-G sample versus a lid that was identified as PET-G through its matching spectrum. This testing was cursory, as with the Cuda, and therefore the techniques used were imperfect. A picture of our experimental setup (pictured with a 100 W bulb that will be discussed in a future subsection) can be seen in figure 20, spectrometer not pictured. The power requirements far exceed our power budget, instantly making this bulb unsuited to our purposes. Additional concerns include potential fire hazard or sample destruction due to the heat output by the lighting system.



Figure 20. Worklight testing setup.

Sylvania 60-Watt Incandescent Bulb

The Sylvania bulb was on the lower end of appropriate lumen output with only 530 lumens. Incandescent bulbs much beyond this range seem unavailable for purchase, presumably because of the nation's push towards more efficient light sources. This bulb consumes 60 W of power - well within our power budget. A package of two bulbs cost \$4.87, which was more than affordable. This power source was also tested, and identifiable spectrums for the three plastics used previously were acquired. Additionally, a spectrum for a random plastic bottle was acquired that matched one of the previously tested known plastics (see figure 17). Upon further testing, it was found that this bulb was too dim for measurements taken from objects more than a few inches away. Additionally, the metal reflective plate would have to be modified for its use.

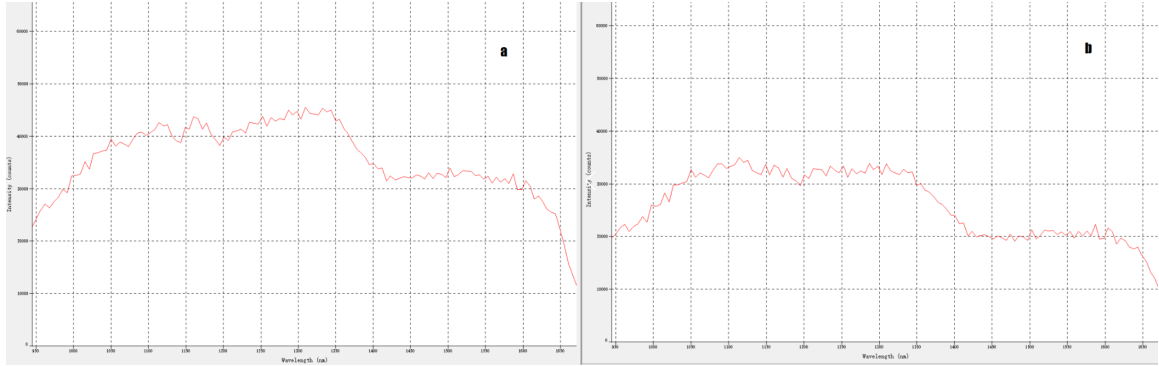

Figure 21. Spectrums taken with a 60 W incandescent of a) a known PET-G sample and b) a bottle identified as a PET plastic. The differences in intensity can be attributed to the fiber being held at different distances from the sample.

FEIT Electric Halogen 100-Watt Bright White Bulb

The FEIT Halogen 100 W was purchased as a possible replacement for the 250 W bulb included with the HDX. It cost \$9.48 for two, and fell well within budget constraints. The 100 W power cost is very high, and almost disqualifies this light source. The temperature of this light is 2700 K, which falls within the desired 2000 - 3000 K. Spectrums were not captured, but a similar experiment as that done with the 250 W halogen was performed and found to be extremely successful. This bulb was a perfect compromise between power budget and lighting requirements.

The following table shows an overall comparison of all of the light sources discussed in this section.

Light Source	Power Consumption	Signal Strength	Cost
Sun	N/A	Strong enough in specific circumstances	Free
FEIT Incandescent	7 W	None	\$6.58
Cuda Optic Fiber Lightsource	0 - 150 W	Strong at 60 W	\$150
HDX Worklight	250 W	Strong	\$12.97
Sylvania Incandescent	60 W	Weak to medium	\$4.87
Fiet Electric Halogen	100 W	Strong	\$9.48

Table 5. Comparison of possible light sources

3.3.4 - Light Focusing Element Selection

Optimal CAWSS performance is heavily dependent on how much light enters the fiber attached to the spectrometer. It has been actively demonstrated by the CAWSS team that this can be achieved in a lab setting sans any sort of focusing element - however, the variable size of incoming waste is expected to cause the in vivo experience to differ. Our original method of simply holding and adjusting the fiber by hand is not practical for the final product. Focusing elements are practically required for proper light collection and product identification to be achieved. The selection of the optical focusing element for the CAWSS is based on focal length, numerical aperture/F-number, cost, and wavelength range.

Thorlabs Concave Silver Mirrors

Thorlabs offers several concave mirrors with various coatings. Aluminum mirrors and silver mirrors from Thorlabs have an identical low price tag when compared to other options. This allows the CAWSS team to choose between the two purely based on the needs of the system. The CAWSS requires maximum light input into the system. The NIR reflectance of aluminum and silver is 90% and 96% respectively, leaving the silver mirror as the only correct choice. The diameter and focal length of prospective mirrors must also be considered, as this will dictate the fiber placement in the system. The ideal location for the fiber is at the focal point of the mirror - too long of a focal point will make the geometry of the system impractical.

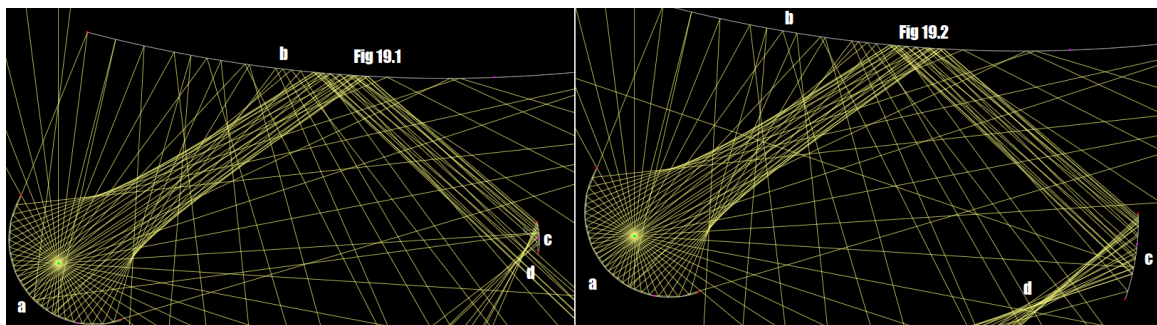

Figure 22. Rough raytrace of the role a mirror would play in the system, with a 1/2 inch mirror in 22.1 and a 2 inch mirror in 22.2. a) the location of the lightsource and the associated reflective backplate. b) the object under consideration. c) the location of the mirror under consideration. d) the location of the fiber optic bundle at the mirror's focal point.

The Thorlabs 1/2" diameter silver mirror offers greater than 96% reflectance for wavelengths between 450 nm and 20 μm . This range covers all desired wavelengths, plus wavelengths needed for the additional Ocean Insight NIR256-2.1 spectrometer to be implemented. It comes with a reasonable price tag of \$39.50 for focal lengths between 9.5 mm and 50 mm. A rough raytrace of this lens's function in the system is pictured in figure 22.1. All 1/2" mirror options have a small focal length; this is acceptable, as the smallest a silver-coated

mirror would theoretically be seeing the incoming light as light from infinity. This would allow all rays to be focused to the focal point of the system, and allow the fiber to collect the most light possible. The small diameter of the mirror would be unable to capture the full amount of light reflected from the surface of the object. This hindrance seems to be of little consequence in the simulation - the sampled ray bundle is still quite thick. The in vivo application of the lens would probably see quite a different scenario - surfaces are not guaranteed to have uniform curvature, and the likelihood of each surface being considerably different is high. This, combined with the imperfect reflectance of the mirror, would provide less light to the system than desirable.

Figure 22.2 displays the effects of a 2" mirror on the same system. Thorlabs offers 2" diameter silver mirrors for \$90.63 that have available focal lengths of 50mm to 1 m. Nearly all light from the system would be captured with this lens. This bundle wouldn't see the rays from infinity, and therefore wouldn't focus all of the light to the same location. This would mean that less of the light would enter the fiber - this would be acceptable, as sheer amount of light collected would well make up for this fact.

Mirrors were ultimately rejected for this project simply because of their nature. If a sample was an unexpected size or shape the likelihood of light being misdirected to an unwanted location is high. It should also be noted, for any future needs, that mirrors from Edmund Optics and MKS are also viable alternatives to Thorlabs.

Thorlabs N-BK7 Plano-Convex Lens (LA1002)

N-BK7 glass has high transmission up to 2um, and is offered in sizes up to 75 mm. Alternative infrared-transmitting materials frequently cost over \$50 for even a 1" lens, making the price tag of \$105.78 seem inconsequential. The 75 mm lens was selected for maximum light gathering capability, and a focal length of 100 mm was chosen. It was originally theorized that a long focal length would make a difference -however, as this is not an imaging system it doesn't actually matter if the image is in focus. The lens only serves as a light gathering element in this case, and does not need to provide an image. Choosing a shorter focal length allows the CAWSS to remain somewhat compact and transportable without the use of mirrors to redirect the light. An AR-coating of 1050-1700 nm was selected in order to maximize transmission in our desired wavelength range. This was only a \$10 increase over the uncoated lens, and was well worth the increased transmission. The reflection in the 950-1050 range is still minimal enough to make this lens a practical choice. The one-component design allows the CAWSS to remain on budget.

3.3.5 - Delivery Mechanism Selection

This section discusses the possible solutions that can be used to physically move the items being sorted by our device. In a broad sense, this system will need to collect items from a user, then align them to our spectrometer subsystem for analysis. Once sorting has been completed, this system will also be responsible for putting items in the compartment they belong. In particular, we are considering either a motorized conveyor belt that will move items linearly, or a carefully designed chute system that will guide them where they belong.

As mentioned in other sections, our device is designed with public spaces in mind. Considering the characteristics of public trash receptacles and the trash they receive allows us to apply some basic constraints to each of our options for this subsystem.

Conveyor Belt System

A conveyor belt is likely the simpler of our two options. A user will place their item on the portion of the belt that sits outside of the device's body. The processor and sensors of our device, discussed later, will detect this event and turn on the belt's motor. The item will be moved to our spectrometer subsystem, where it must be aligned correctly for spectral analysis. This system will need to account for the proper alignment of items along the width of the belt, as all of our optical components will be aimed at a fixed point. This is simplified somewhat by the fact that this subsystem only needs to handle common trash in a public space; we believe the width of our conveyor belt can be limited to under one foot.

This option does present several challenges, especially related to the material used for the belt. The belt must be sturdy enough to not flex under the weight of any items. While we do not expect to test this prototype outdoors, we must also choose material that can withstand some exposure to water and heat. Most importantly, materials which reflect in the NIR spectrum should be avoided to prevent interference with spectral analysis.

Conveyor Belt Material Options

Industrial-grade conveyor belts made of rubber or metal may be a good option for this component, but these are typically only available for large, industrial orders and therefore inaccessible to us. One similar replacement would be the large "walking belt" from a treadmill. These are very sturdy, but may cost anywhere from \$60 - \$90 when bought as a standalone, new part. A cheaper way to source this for prototyping purposes would be to find a used treadmill, which we would take apart to reuse the belt and other components.

An even more accessible alternative would be a material called “blackboard fabric” from a local craft store. It costs \$7.99 per yard, and would be much easier to cut as needed for our design than the treadmill’s thick rubber. This material is intended, as the name implies, to be stretched across a surface for writing. However, we found that it was one of the sturdiest materials available at these stores.

Chute System

Our second option has fewer moving parts, but requires much more preliminary planning. For this system to work correctly, the chute would need to somehow guide and align falling items of varying sizes to the point where our spectrometer components are focused. We intend to explore this option regardless, as it would be significantly easier to maintain and clean. For the time being, we are proceeding development of the optical system for our first demo on a flat surface, and will adjust as necessary in Senior Design 2 to the decision made for this component.

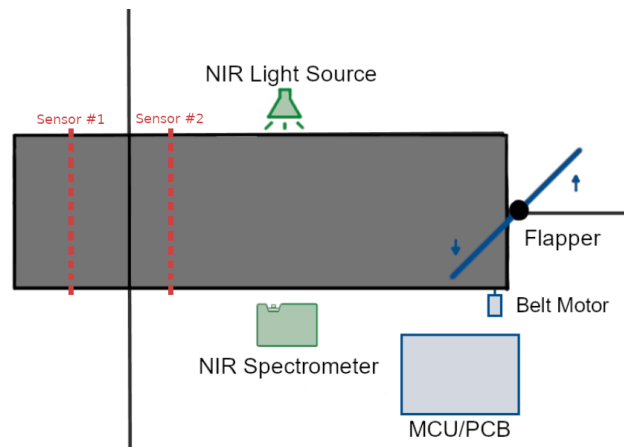

Figure 23. Diagram of Sensor #1 and #2 position

3.3.6 - Sensor Selection

This section specifically deals with sensors used in the device that are separate from those used for the spectrometer. Our design calls for at least two of these sensors, at the positions shown in the diagram below. The first, Sensor #1, will trigger an interrupt service routine that will wake all components from their low-power states. The second, Sensor #2, will be used to infer when an item is properly centered for spectral analysis.

Complicating this decision is the fact that Sensor #2 may interfere with spectral analysis. For example, a sensor that uses an infrared LED would emit light in the NIR range of our spectrometer. Such a sensor must either be kept isolated from the spectrometer, or avoided entirely in favor of a system that emits no light in the NIR spectrum. For this reason, our requirements include additional focus on choosing a sensor appropriate for use inside the device.

5.1	Consume a minimal amount of power.
5.2	Can produce an interrupt signal to wake a processor from LPM.
5.3	Produces minimal interference in the NIR spectrum.
5.4	Reliably able to detect item at sensor position.

Table 6. Technical Requirements for Device Sensors

IR Sensors

This sensing mechanism is similar to a traditional tripwire, perhaps most commonly used today as a safety sensor for garage door openers. An IR LED sits at one end, and an IR sensing photodiode sits at the opposite. In its default state, the LED is unblocked and the diode receives the full, expected intensity of light. When the LED is blocked and it receives less light, an event is triggered.

In technical terms, this sensor should read as a digital HIGH input (likely via an MCU's internal pull-up resistor) when not tripped. When an object crosses the sensor, the input will fall to a digital LOW - this falling edge should trigger an interrupt service routine that progresses to the next part of the sorting process.

As mentioned before, this type of sensor will emit light in the same range our spectrometer is using to perform analysis. To use this sensor effectively in our design, we would have to test its effect on our data. If the effect is significant, we will take measures to remove this interference, by either angling or blocking the LED such that it will emit no light towards the spectrometer.

Color Sensor

A color sensor uses several elements to measure the color of an object in front of it as accurately as possible. The Flora Color Sensor we are considering also includes an IR blocking filter and standard LED to illuminate the object being measured. In effect, this is a more sophisticated version of the previous sensor in a different light spectrum.

These devices are complex enough to require communication over I2C, so the sensor will need to be actively monitored over an MCU's I2C pins. Our software must monitor for changes in color value from the baseline (taken with no item in front of the sensor). This makes it unlikely that this sensor can be used to trigger an interrupt on its own. However, it is significantly less likely to cause interference with our spectrometer, making it a good candidate for Sensor #2 as long as an interrupt-capable sensor is used for Sensor #1.

Design Matrix for Sensors

The following design matrix rates these sensors on their ability to meet these requirements. As there are only two sensors in consideration, a rating of 2 represents the best option, and a rating of 1 represents the worst. In cases where they are equally good, a rating of 1 will be given for both.

Sensor	5.1	5.2	5.3	5.4	Total
IR "Tripwire" Sensor	2	2	1	1	6
Flora Color Sensor	1	1	2	1	5

Table 7. Design Matrix for Sensors

The design matrix shows that our options have about as many strengths as weaknesses. We will likely purchase one of each, and use them where suitable in the design. Ultimately the Infrared Emitter and Detector couple available on Sparkfun (SEN-0024) for \$1.95 are good candidates for infrared testing. These are two separate units, but can be configured for use as needed.

3.3.7 MCU Selection

An MCU is ideal for controlling many parts of this project. They provide the most flexible input and output interfaces of any option, include hardware timers for PWM motor control with little CPU overhead, "low-power modes" that are ideal for reducing idle power usage when the device is not in use, as well as the hardware interrupts necessary for reliable performance in an embedded environment.

The main weakness of an MCU for our design is the fact that there are no existing tools it can use to communicate with the FlameNIR. We would either need to design and implement a USB driver specifically for our MCU to communicate with the Flame, or reverse-engineer its largely undocumented expansion port. Both of these options would be unsupported by Ocean Insight, and require greatly increased development time. To mitigate these issues, we will use a more powerful secondary component as a coprocessor for our system, to communicate with the Flame using existing USB-based software as well as to analyze spectral data. This secondary component is discussed in far greater detail in the next section of this paper (3.3.8).

The MCU included in our design will be used entirely for the lower-level tasks in the system, such as detecting sensor inputs and controlling motor output. When a piece of trash arrives at the appropriate point on the conveyor belt to perform

spectral analysis, the MCU will send a pulse to notify the secondary coprocessor. The result of that processor's spectral analysis will be sent to the MCU as a simple digital output, and the MCU will simply match that output to a servo output that will direct the item where it belongs.

MCU Options

Microcontrollers offer a wide variety of specifications and capabilities. Our requirements for this component are very modest, since our secondary processor (discussed in section 3.3.8) will be responsible for communication with the Flame and spectral analysis. For this reason we are not including performance as a technical requirement: all the MCUs in consideration would easily exceed this requirement. Similarly, our input/output needs are modest as well and also excluded from our requirements, since the MCU will be connected to a small set of fully digital components that each require no more than 2 pins to communicate. The following table (table 8) lists our design's technical requirements for this component.

6.1.1	Minimize unnecessary development time.
6.1.2	Minimize cost.

Table 8. Technical Requirements for MCUs

We chose several MCUs for consideration. The ATmega2560 was chosen because it is extremely easy to develop for via the familiar Arduino platform, and we also consider a MSP430 processor for its low cost and familiarity thanks to our use of these processors in our Embedded Systems and Junior Design courses. The group members who will be responsible for programming the MCU are equally experienced with each, but we believe the Arduino development tools available for the ATmega will significantly reduce development time compared to Texas Instruments' Code Composer Studio.

The RP2040 is newer, released in 2021 as the Raspberry Pi Foundation's first fully-embedded MCU product. It offers an interesting, powerful new platform at a similar price to the TI chip, but will require some additional development time to learn to use. Nonetheless, we found that the RP2040 is very well documented and will likely be easier to develop for than the MSP line of processors, which requires the use of the powerful, but less friendly Code Composer Studio. It is primarily included for the sake of future expansion to our project; this MCU is by far the most powerful option, and would be preferable if we wished to fully move all of our software onto a single processor, without the use of an additional coprocessor. However, this would require significant additional development time, and is as such not considered an important factor for our MCU component decision.

The following table lists the most relevant technical specifications of these three options. Many of the pins on these devices are multi-purpose, so the “Digital Pins” specification refers to the total number of pins available to allocate on an MCU for use in digital input/output. The RP2040 notably does not include flash storage on-chip, so its \$1 list price is not entirely accurate; the cost of a compatible 16 MB flash module is included in this chart.

MCU	CPU Clock	Digital Pins	RAM	Flash Storage	Price	Supplier
ATMega2560	16 MHz	54	8 KB	256 KB	\$6.35	Digikey
RP2040 + external flash	133 MHz (Dual-core)	30	264 KB	16 MB (external)	\$3.72	Digikey
MSP430G2553	16 MHz	24	0.5 KB	16 KB	\$3.38	Digikey

Table 9. Relevant MCU Technical Specifications

Below, we present a design matrix to rank these choices before listing the specifications of our chosen MCU. For each category a rating of 3 is the best possible score, and a rating of 1 is the worst possible score. Our modest technical requirements leave all of these options functionally equivalent in this simple table - especially since the importance of requirement 6.1.1 is somewhat inflated. In reality, a cost difference of no more than \$3 is negligible, and the most important category for this decision is 6.1.2.

MCU	6.1.1	6.1.2	Total
ATMega2560	3	1	4
RP2040	2	2	4
MSP430G2553	1	3	4

Table 10. Generalized Design Matrix for MCUs

Using requirement 6.1.2 as the primary driver for our decision, the best option for our MCU component is to use the ATMega2560. It is by far the easiest MCU to develop for, and the cost increase compared to our other options is negligible. The RP2040 provides a promising new platform that we would have liked to explore for the sake of learning it - however, it is undeniable that its newness would inflate the time needed to properly implement this processor and program for it. The MSP platform is the cheapest of all, but a savings of \$3 is not significant.

3.3.8 - SBC Coprocessor Selection

As discussed in the previous section, communicating with the FlameNIR presents a unique challenge. Rather than waste development time reverse-engineering the Flame's expansion port or USB driver, we will be using a single-board computer (SBC) with existing USB-based software.

Originally, we considered several different components for this task. This was largely due to the limitations of Ocean Insight's officially supported software solutions for the FlameNIR. Our design requires a degree of automation that the OceanView imaging software cannot provide. The company does offer OmniDriver, a closed-source tool providing control and analysis of data from spectrometers like the Flame - however, this is only available for x86 platforms. This is obviously not an ideal solution for an embedded system; embedded solutions that use x86 exist, but they are generally reserved for high-cost, low-volume industrial appliances. There are some relatively low-cost x86 SBCs available for purchase, but they are all at over double the price of all of our other options.

Thankfully, the open-source SeaBreeze API widens our options significantly. This API was originally developed by Ocean Insight themselves (although it is largely unmentioned on their official sites). The API provides all the functions necessary to command and receive data from the FlameNIR through standard C OS-agnostic libraries, taking care of these low-level tasks but leaving spectral analysis fully up to the software developer to design. A community-made Python module (`python-seabreeze`) provides all of SeaBreeze's functionality in the Python language, where it can be used in conjunction with numerous statistical analysis libraries, and extends it somewhat to spectrometers not supported by the original SeaBreeze as well (though this is not necessarily needed for the FlameNIR). The open-source nature of this API means we are no longer limited to x86 components, and can optimize our design much more effectively.

Technical Requirements and Specifications

The following table shows the technical requirements our selected processor must meet:

7.1	Processor must perform spectral analysis with acceptable speed.
7.2	Chosen component should minimize cost.
7.3	Chosen component should minimize development time.

Table 11. Generalized Technical Requirements for SBC

In consideration are some of the Raspberry Pi line of SBCs, chosen for their familiarity and variety of offerings. Particularly, we are considering the most recent revision of the Raspberry Pi, as well as the Pi Zero W. The differences between these are obvious, with Zero products offering more modest performance at a much lower price. Despite its much greater cost, we have also included one of the x86 SBCs we considered before finding the SeaBreeze API in order to provide some context for our original constraints.

The following table lists the most relevant specifications of these three options:

Processor Option	CPU	RAM	Architecture	Power	Price
Raspberry Pi 4	4 cores, 1.5 GHz	2/4/8 GB	ARM32/64	15 W	\$35/45/55
Raspberry Pi Zero W	1 core, 1 GHz	512 MB	ARM32	5 W	\$10
LattePanda SBC	4 cores, 1.8 GHz	2/4 GB	x86/x64	10 W	\$99.00

Table 12. Relevant Processor Technical Specifications

The following design matrix rates each processor option on its apparent ability to meet the technical requirements mentioned in the beginning of this section. A rating of 3 is best, a rating of 1 is worst.

Generalized Design Matrix for Processors

Processor Option	6.1	6.2	6.3	Total
Raspberry Pi 4	3	2	3	8
Raspberry Pi Zero W	1	3	2	6
LattePanda SBC	2	1	1	4

Table 13. Generalized Design Matrix for Processors

According to our research and design matrix comparing these processors' specifications, the best of our options is the Raspberry Pi 4. We have performed all testing of our preliminary analysis software on this device already (specifically the version with 4 GB of RAM), and have verified successful communication with the FlameNIR. Data collection takes less than 1/5 of a second, even on the Pi, and our preliminary software's comparison functions execute with similar speed.

The LattePanda SBC is thus simply unnecessary for our project; not only does the Pi 4 more than meet our requirements, but the use of the SeaBreeze API, rather than OmniDriver, means we are not limited to using x86 systems for our analysis software. This rules out our most expensive, lowest-rated option. The Pi Zero may offer acceptable performance at a lower cost when tested, but there are not enough reasons to move from the Raspberry Pi 4 we are already using for development. We will continue developing our design using the Pi 4; however, we realize in the later stages of the process that the cost savings of the Pi Zero are necessary, porting our software to it will be incredibly simple.

3.3.9 Voltage Converter Selection

Linear voltage regulators are devices capable of transforming a higher input voltage into a lower output voltage. These DC-to-DC converters are typically used in integrated circuits and can be manufactured in a very compact form. A linear voltage regulator in its simplest form can be constructed in a breadboard with resistors, one transistor, and one operational amplifier. These three elements can be arranged to sustain a constant voltage at the output regardless of the load resistance. To achieve this, the load and a feedback loop will be connected to the emitter of an NPN transistor; the feedback loop attaches to the inverting terminal of the op-amp while the non-inverting terminal is connected to the input voltage. Using the resistors to create voltage dividers within the feedback loop and the input voltage, a designated voltage at the emitter of the transistor can be established since the output of the op-amp will be connected to the base of the transistor. Any current fluctuation, product of a variation in the load resistance, will be sensed by the feedback loop and a proportional reaction will ensue towards the base of the transistor thus sustaining the voltage at the emitter.

In practice, this mechanism is achieved through a compact array of transistors similar in construction to an operational amplifier. A popular linear voltage regulator such as an LM7805 contains a Zenner diode and at least 15 BJT transistors. This simple design allows linear regulators to be inexpensive and are not susceptible to noise. However, this basic composition also implies low power efficiency as excess current is diverted from the output to achieve voltage regulation, incurring in wasted power. For this reason, linear voltage regulators are implemented for small DC-to-DC voltage differentials such as integrated circuits. For large voltage differentials, such as 120V to 24V, switching voltage regulators must be utilized.

Switching voltage regulators do not have a basic composition since the output is typically coupled to the input via a transformer arrangement, which additionally switches on and off at different frequencies to maintain regulation. This system allows for a much greater efficiency since switching the voltage on

and off reduces power usage. However, this greatly efficient design requires comparators, oscillators, inductors, and a higher count of transistors and capacitors. In essence, switching regulators utilize a PWM sub-system that increases or decreases the pulse width (transistor enable time) inversely proportional to output voltage. This switching DC voltage output is finally smoothed via inductors and capacitors. Switching voltage regulators are also found in small voltage differential circuits, such as battery powered integrated circuits that require low power consumption; these regulators do not couple the output with a transformer and still retain high power efficiency.

Furthermore, switching voltage regulators are commonly the type of instrument utilized for AC to DC voltage conversion. Placing a rectifier/smoothing circuit prior to the switching voltage regulator is the only requirement for adapting the previously discussed DC voltage regulator to AC voltage conversion. A rectifier is a circuit element composed of diodes that reroutes the negative cycle of AC power to make a one-way current path with the positive cycle. Once the input voltage is rectified and smoothed, the switching voltage regulator can step down the voltage.

Due to the number of different components and switching nature of these regulators, they can be susceptible to noise. Additionally, linear and switching voltage regulators have a minimum input voltage rating necessary to maintain regulation. Linear switching regulators can commonly be found in low dropout voltage configuration whereas switching voltage regulators require a higher dropout voltage. These big differences between both types of voltage converters make each type of component specific to different types of applications.

3.3.10 Solar Panel Selection

Solar panel selection must be made mostly on the estimated power needs of the system. It is possible that, as these needs evolve, some of the power needs will be fulfilled with wall power. The solar panel portion of this design mostly serves as a demonstration of the ability to apply solar power to waste recycling to create an all-green recycling system. Full application would require more space and funding. Considerations to be made are efficiency, cost, and size. Alternate solar panel positioning might be considered to add more solar panel coverage for the system. 12-Volt output is needed for our system if downconversion is to be avoided (and, thus, extra cost). It should be noted that power supplied varies with sun location and temperature, and should ultimately be accounted for when considering power supplied. Nearly all panels over 100 W were far beyond our budget constraints. Table 14, located at the end of the panel option descriptions, summarizes the panels considered.

Renology 12 Volt Compact Panel

This solar panel option has a light aluminum frame and features corrosion-resistant cells. 100 W and 200 W options are available for purchase, and measure 3.5 x 1.6 feet and 5.3 x 2.2 feet, respectively. The measurements of the 100-W panel are well within our space limitations, and therefore is a strong candidate for our purposes. The 200 W panel is a little more intimidating, and is possibly on the upper end of our space capabilities.

Cell efficiency of these solar cells is 21%, which is considered to be fairly good for solar cells. Both panels feature waterproof electrical connections and drainage holes, and both meet the 12V system requirement. The cost for the 100-W panel is \$103.44, which is considered to be in budget. The 200 W panel comes with a hefty \$252.44 price tag. This cost, when combined with the space requirements, makes the 200 W panel significantly less desirable than the 100 W. This unfortunately comes with the tradeoff that only about half of our system would be powered via solar collection. The 100 W panel was ultimately selected for purchase.

Grape Solar 50 Watt Panel

This 2.2 x 2 foot solar panel is a cost-efficient way to fulfill our power needs. It only costs \$55.41, making it a prime candidate when multiple cells are desired. The frame's material and weather-proofing measures are not listed. The cell efficiency of this panel is only 12.5%, indicating that the quality of the material isn't high. One panel is only about a quarter of the energy we initially wanted to use - however, if three of these panels are purchased 150 W of energy will be supplied, and our cost will only be \$166.23- far less than the 200 W panel option presented previously. The space consumed would be a 2 by 6 foot area, which would provide space challenges to our design. Alternative side-mounted configurations might make a three-panel configuration practical. The small size of each individual panel would make this possible without costing an excessive amount of money. This option, although desirable, was ultimately not selected because the side-mounting of the third panel was not part of the CAWSS original design. It offers an excellent option for future designs, or designs attached to light poles or other solar panel carrying appliances.

Mighty Max 100 Watt Panel

This \$110 panel comes with pre-attached MC4 connectors and pre - drilled mounting holes. It has an aluminum frame, similar to the Renology option. It measures 1.9 x 4 feet - marginally larger than its Renology counterpart. Its efficiency specs were not listed. Since this panel was only marginally different from Renology - a bestselling panel - it was not selected for purchase.

Manufacturer	Power Supplied	Size (Ft)	Efficiency	Cost
Renology Compact Panel	100 W	3.5 x 1.6	21%	\$103.44
Renology Compact Panel	200 W	5.3 x 2.2	21%	\$252.44
Grape Solar	50 W	2.2x2	12.50%	\$55.41 x3
Mighty Max	100 W	1.9x4	unknown	\$110

Table 14. A comparison of considered solar panels.

3.3.11 Solar Panel Accessory Selection

Solar panel systems require an inverter, a charge controller, and a battery. This section discusses how each was selected. Comparisons of specific parts will not be made, as these items are fairly general.

Inverter Requirements

An inverter should be selected on the expected peak load on the system and the surge rating. Our maximum load for the entire system will occur when the optical system is active - i.e., when the light and spectrometer are on. Minimal load will occur when no waste is in the system, and medium load will occur with the conveyor belt, servo motor, and sensors running. The maximum load on the panel system is expected to be roughly 100 watts since only the conveyor belt, sensors, and servo motor will run off of the solar panels. The Ridgid RD97100 100 Watt Power Inverter was chosen for this purpose - it's a car charger inverter, but that portion can just be removed and replaced with the appropriate wiring to connect to the solar panel. Only car charger inverters were available at this output level.

Battery Selection

Run time expectations must be set before a 12 V battery can be selected. Initially our team looked at planning for 5 hours of 250 W runtime (with losses) - however, this was not financially feasible (a battery this large can cost almost \$200!) or completely needed. The 250 W max power draw would only be required periodically since the conveyor system is only on when trash is inside and the optical system is only on when it's sampling trash spectrum. This enables the CAWSS to be fairly energy efficient and allows us to implement a much smaller, much more affordable battery.

The exact runtime of the different elements is not known currently, as not every component in our design is fully known. A 3 hour run time at max output was considered, but this too proved more expensive than is practical. Eventually, a 1 hour run time was agreed upon. This would require roughly 20 amp hours of supplied battery time. Charge can be accumulated via the solar panel between uses if our project is set up outside, and additional batteries can be added to the configuration if our tests deem it necessary. A summary of the various batteries' characteristics and the associated cost can be seen in table 15. Ultimately the ExpertPower 20 AH lead acid battery was selected for purchase.

Maximum Runtime (hours)	Watt Hours	Amp Hours	Average Battery Cost
5	1875	156.25	\$180
3	750	62.5	\$160
1	250	21	\$40

Table 15. Summary of battery run times considered and their associated costs.

Charge Controller Selection

The charge controller functions to make sure that the batteries charge properly, and don't take more charge than they can handle. The size of the charge controller was found by dividing the solar output by the battery voltage - this resulted in the need for an 11 amp charge controller. Two types of charge controllers are commonly used for solar power - Pulse-Width Modulation (PWM) controllers and Maximum Power Point Tracking controllers (MPPT, which runs off an optimization process) . The first option is generally cheaper than the latter, with controllers in the \$15-\$30 range vs the greater than \$100 range. The Binen 20 A solar charge controller was chosen. It's efficiency is unfortunately only 50%, meaning that our battery will take longer to charge. This loss in efficiency was made worth it by the cheap, \$16.99 price tag. The max amperage of 20 amps shouldn't make a difference in the controller's performance.

3.4 - Possible Architectures and Related Diagrams

Show below are a couple examples of early design architectures that our group examined.

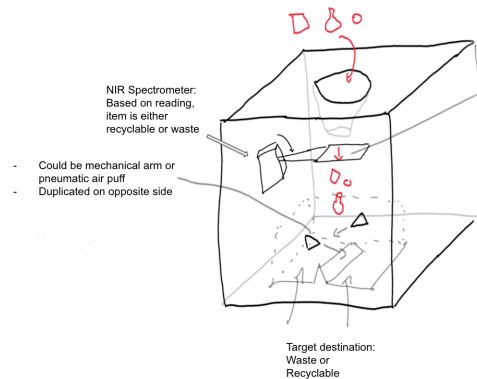

Figure 24. First Initial Design for CAWSS

Our team's first initial design for CAWSS was going to be built around the concept of a gravity chute, where the trash would free-fall down the device and it would be during this free fall that the spectrometer would take a reading of the material and perform the analysis. After a decision was made in the analysis, either a mechanical arm or pneumatic air jet would then move the trash to its appropriate bin and the job would have then been completed.

Several limitations and challenges arose when taking a deep dive into the technical details of this design. The most important for determining if this was a feasible design was the processing time that the spectrometer and software needed to capture an accurate spectrum and make an informed decision on where the waste should go. Due to the weight of the item dictating that rate at which it fell towards the bottom, our spectrometer and software did not have ample time to capture an accurate spectrum of the material. Another limitation to this was that the height of the device itself, in order to have sufficient waste capacity, needed to be taller than the average person is capable of reaching. This was a limiting factor when in contrast with a conveyor belt design where the length of the device is not a limitation to the consumer.

Our team's second initial design of the CAWSS is much closer to our current design because they are both based off of a conveyor belt being used as the primary delivery mechanism for the waste. It involves waste being fed into a hopper where it is directed onto a conveyor belt. In this design, a line scan from the spectrometer will be taken of the object and the data will then be analyzed by the software. After this, a mechanical arm or pneumatic air puff could then be used to put the waste into its proper destination. This design is very similar to the design that our group has chosen to use with the exception of the line scan. In our testing, the line scan was not found to be necessary to obtain an accurate spectrum of the object. A point scan is sufficient enough to get an accurate spectrum to differentiate the spectrum from that of other material types.

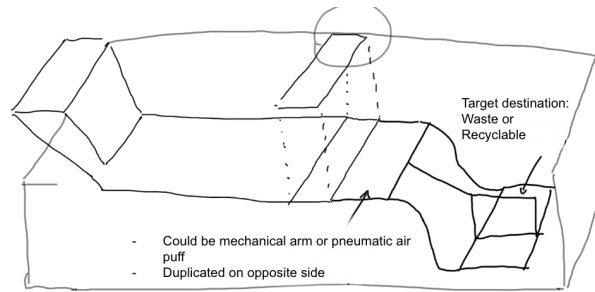

Figure 25. Second Initial Design of CAWSS

3.5 Optical Component Selection Summary

This section details how the calculations for each optical component were performed per request of the Photonics department. The light source, lens, and fiber are covered here. All calculations are based on the spectrometer's required minimum light intake, which is calculated in the section below. A plan detailing future Zemax simulations is presented for extra analysis.

3.5.1 Spectrometer Input Requirements

Some basic calculations were made to understand the Flame's needs and abilities. The Rayleigh Criterion corresponding to the input slit was found to be 2.934 degrees when the formula $\sin\theta_R = \frac{\lambda}{d}$ was applied to its 25 μm slit with λ being the center wavelength. The Flame's detector is a Hamamatsu G8160-03 InGaAs with 128 pixels. Using the equation $\frac{\text{spectrometer range} * \text{pixel resolution of detector}}{\text{number of pixels}}$, the FWHM resolution was found to be 1.9 nm. It is to be noted that this photodetector is a line scan detector, and each pixel is impacted by a different wavelength of light after the incident light passes through a prism.

The Flame's light requirements can be found by considering the noise floor of the detector. The Flame's noise floor is around an average of 9 photons. Any light reaching the spectrometer that exceeds this number will yield a signal. This is critical in both light source and optical component selection. The following sections will use this noise floor to justify the selection of all components, working from the fiber to the light source.

This justification will be aided by calculating the Flame's étendue (possible light throughput or light acceptance capacity). This can be done with the equation $G = \pi * S(NA)^2$, where G is the étendue, S is the area of the source, and NA is the numerical aperture of the spectrometer. Conveniently this allows us to understand that we can simply match numerical apertures instead of finding the étendue of each component. This numerical aperture matching allows us to

have the same amount of étendue through the entire system. The numerical aperture of the Flame is 0.22 as dictated by the Spectrometer's collimating mirror. This provides an étendue which matches the fiber étendue described in the next section.

3.5.2 Fiber Selection

The amount of light that can enter the optical system is controlled by the slit in the spectrometer itself. The chosen spectrometer (whose selection is detailed in 3.2.2) has a slit size of 25 μm . Most fibers available have core sizes of 50 μm or greater - this means that at least half of the light collection will not be allowed into the system. A larger core size bears its own benefits: its étendue is much higher than that of a smaller core. The étendue of a fiber can be calculated with the equation $\text{étendue} = \frac{\pi^2}{4} * d^2 * NA^2$, where d is the core diameter and NA is the numerical aperture. The core area above serves as the source area in the spectrometer étendue. This makes it clear that numerical aperture matching will serve our purposes without issue. The numerical aperture of the fiber selected is 0.22, and the core is 200 μm . This provides us with an étendue of 4.77×10^{-9} . This étendue is the same étendue the spectrometer sees (minus some blocked by the slit), as it acts as the light source for the system and the numerical apertures are matched.

3.5.3 Lens Selection

A properly matched lens will act as a light source for the fiber. The $F/\#$ of the lens was first calculated with the equation $N = \frac{f}{D}$, where f is the focal length and D is the lens diameter. The selected N-BK7 plano-convex lens had a 75 mm diameter and a 150 mm focal length. This resulted in an $F/\#$ of 2. The $F/\#$ was, in turn, used to calculate numerical aperture with $NA = \frac{1}{2*NA}$, giving us a NA of 0.25 - slightly larger than the fiber. This is of little consequence - the mismatch is small enough that only a small amount of rays escape the fiber aperture. The étendue of the lens is based on the étendue of the light source; therefore, the étendue of the lens will be discussed in the next section.

3.5.4 Light Selection

First, as stated in section 3.3 it should be noted that LEDs were not considered due to their small bandwidth - an impractical number of LEDs would have to be utilized to achieve the broad wavelength band needed for the spectrometer to operate correctly. All of the appropriate light sources to be considered were lamp-like sources in the form of bulbs. These bulbs are considered to be extended sources because of their enormous size in comparison to the spectrum slit width.

The area of the chosen 100 Watt halogen is considered to be the area of the filament, and is 50 mm^2 . This is used in the étendue equation $G = \pi * S * \sin^2(\Omega)$, where S is the area of the source and Ω is the light's solid angle. This yields an étendue of 1.57×10^{-4} when a solid angle of 90 degrees is considered. This large light étendue is of little concern, as the lens, fiber, and slit only receive a portion of the light output - most of the light escapes in other directions when reflected off of a spectrometer sample. Indeed, it's hard to actually predict how much light is reflected from the source in order to calculate the exact amount of light in the system. The lack of exact reflection data allows us to only make hand flux calculations based off of theoretically directly incident light. This requires us to perform Zemax simulations next semester to verify that the theoretical data is correct.

The lens's ultimate étendue is 7.6×10^{-6} - the mismatch in étendue is of little concern although this is 5 orders of magnitude larger than the fiber's possible étendue. The NA of the systems are still matched, so the ray bundle at the focal point is diverging in a manner in which the fiber will accept all incoming rays. Any excess will be reflected out of the system. It again should be noted that the actual étendue of the system is much lower due to the light only reflecting off of the bottle in a small area - the actual size of the reflected halogen lamp light is only a quarter or so of the original source. This estimation gives us an étendue of 1.9×10^{-6} . The purpose of choosing such a lens was to collect the maximum amount of light being output by the system.

This then brings up an important point about lens location - the object should be at the lens's front focal point and the fiber input should be at its rear. This positioning allows the lens's numerical aperture to be properly utilized, and assures that the fiber accepts the maximum amount of light. The light itself is positioned so that its reflection is roughly $\frac{1}{4}$ the original size, as outlined in the above paragraph.

The needed wattage of the light was determined through a variable light source, as outlined in section 3.3. This was done through manipulating the equation for luminous efficiency, $\eta\left(\frac{\text{lm}}{\text{W}}\right) = \frac{\Phi_v(\text{lm})}{P(\text{W})}$, where Φ_v is the luminous flux and P is the power supplied. The luminous efficiency of various sources is well documented, and allows an equation to be manipulated for power or lumens, respectively. The selection of an appropriate source can be made by considering the minimum light required by the detector and working backwards.

3.5.5 Final Incident Light Calculations

The minimum photons required for the detector to exceed its noise threshold is 10 photons. Despite luminous flux being discussed in 3.5.4, the appropriate measure to be used for photon count is irradiance. Finding the minimum irradiance of the system starts with finding the energy of a photon in the center wavelength of the detector's range - 1250 nm. Using $E = \frac{hc}{\lambda}$ it is determined that the energy of a single photon of this wavelength is 1.59×10^{-19} Joules.

The desired irradiance incident on to the detector can be found through manipulation of the equation $N_p = \frac{I}{E_p}$. Since 10 photons is the minimum and the photon energy was found above, the required irradiance is $1.59 \times 10^{-18} \frac{W}{m^2}$. This very small number can be satisfied simply by finding the minimum étendue that's required for the spectrometer to function.

The étendue incident upon the photodetector is limited by the smallest étendue of the system. This is nearly always the slit, as it has the smallest aperture size of any component in a spectrometer's optical setup. The system étendue can be calculated by the equation $G = \frac{h*n*k*GA*BP}{F*1 \times 10^6}$, where h is the height of the entrance slit, n is the groove density of the grating, k is the order, GA is the grating area, BP is the bandpass, and F is the focal length. Unfortunately most of this information is proprietary to Ocean Insight and unavailable for our use. This makes finding the limiting étendue impossible, and therefore the spectrometer's étendue will just be used.

The calculated minimum irradiance must be converted to the directional radiance before the étendue calculation can be performed. The equation to calculate radiance from irradiance is $R = \frac{I*d^2}{A}$, where A is the source area and d is the distance between the detector and the source. Using a small angle approximation, this is collapsed down to $R = I * \theta$. Since the numerical aperture of the spectrometer is 0.22, the maximum acceptance angle can be calculated with $NA = \sin(\theta)$. This provides an acceptance angle of 12.7 degrees, or 0.2218 radians. Using the above equation, $R = 3.527 \times 10^{-19}$.

Knowing the radiance allows the minimum radiant flux to be calculated for the system through the equation $\phi = R * G$. Therefore, the system's minimum radiant flux is 1.683×10^{-27} . The Zemax test plan for verifying that the light provided exceeds this will be outlined in the next section.

3.5.6 Zemax Test Plan

The radiant flux through the system will be determined next semester with Zemax. The light source chosen was selected semi-qualitatively through the luminous efficiency equation outlined in section 3.5.4. This will be accomplished by either importing or creating the applicable components used. A light source the size and brightness of the approximate reflected image of the currently selected source will be applied. The flux through the system will then be measured. Once this is complete, a source that would match the minimum required flux would then be tested. These two tests will confirm the validity of the above mathematics and the selected light source. This is expected to provide more accurate results than hand calculations, as the slit's effect on the system should be observable even without spectrometer specifics.

3.6 - Parts Selection Summary

A summary of parts selected is presented in table 16a and b (on the following page). These selections represent our final decisions, and will not be changed unless a selection is found to not fulfill its requirements. The ultimate bill of sales can be found in section 8.3.

Item	Part # or Name	Manufacturer	Price
Spectrometer	Flame NIR	Ocean Insight	Borrowed
Light Source	#BPQ100T3/ CL/S/2/HDRP	Feit	\$9.48
Light Housing	#265669	HDX	\$12.97
Lens	#LA1002	Thorlabs	\$105.78
Fiber	#FG200UEA	Thorlabs	\$125.53
Conveyor Belt Material	TBD	TBD	TBD
Conveyor Belt Motors	12 V DC 3200 RPM Motor	N/A	\$5.95
Sensors	#SEN-00241	LiteOn	\$1.95 x 2
MCU	ATMega2560	Digikey	\$6.35

Secondary Processor	Raspberry Pi Model 4B	Raspberry Pi	\$38.88
---------------------	-----------------------	--------------	---------

Table 16a. Part Selection Summary

Item	Part # or Name	Manufacturer	Price
Voltage Converter	#LM1084IT-5.0	Texas Instruments	\$3.03
Voltage Regulator	#LM1085IT-3.3	Texas Instruments	\$2.20
Solar Panel	#RNG-100D-SS	Renology	\$103.44
Battery	#EXP12200	ExpertPower	\$40
Charge Controller	#4332694907	Binen	\$16.99
Inverter	#SG_B00KBA992Y_US	Rigid	\$35.58
PCB	4 layer PCB (2 revisions/orders)	OSH Park	\$140.00

Table 16b. Part Selection Summary

4 - Related Standards and Realistic Design Constraints

This section discusses the unique standards that are applicable to our project as well as design constraints necessary and how these affected the development of our concept. Many different considerations of design constraints were given weight when designing, developing, and troubleshooting our concept.

4.1 - Standards

As discussed previously, while there may not be a specific standard describing the device we have set out to design, there are many standards which can be applied to its components. A crucial place to start are the general standards regarding the recycling of plastics.

Much of the ISO standard for Plastics Recycling (ISO 15270:2008) is in reference to the industrial processes used to reclaim usable material from plastics. However, parts of this standard do fall under the high-level scope of our project. Definitions of plastic types, as well as which ones are considered “recyclable” will guide the spectral analysis that is the core of our design.

Many different standards can be applied to the electrical components of our design. At the lowest level, we must follow some of the basic guidelines for proper PCB design (IPC-221B). Beyond this, there are several standards that apply to our power systems; our solar panel, battery, backup AC-DC converter, and even the simple DC-DC conversion circuits in our design must all be designed to respect the safety standards for these types of systems. Following all of these standards for electrical systems will ensure that we lower all possible risk of fire, electrical, and chemical hazards, which will be extremely important for a device intended for public, outdoor use.

Our device is intended for use by customers who will be manually emptying it of trash/recyclables and moving them to a secondary receptacle (such as a dumpster), rather than fully replacing a user’s bins or dumpster. For this reason, any state or local standards for bins do not apply to this design. However, a few standards do apply to parts of this design, such as standards for power supplies and PCBs.

4.1.1 - Power Supply Standards

IEC 60906-2:2011

This standard describes the NEMA 5-15-P, otherwise known as the ubiquitous “3-prong grounded plug”, providing 15A 125V AC or 20A 125V AC. It also explains that this type of connection provides protective earthing to any equipment connected to the conductive parts of the socket, and electronically separates this earthing from the rest of the cabling to reduce electrical noise.

This standard applies to our system, which will use a standard North American wall outlet as a backup power source. The IEC 60906-2: 2011 standard describes all the requirements to be compatible with these outlets and cables, and critically also helps isolate our system from electrical noise.

4.1.2 - PCB Standards

IPC-2221

Our system will be using at least one printed circuit board to connect all of the parts of our design. The Association Connecting Electronics Industries, otherwise known as the Institute of Printed Circuits (IPC) set some standards for all types of printed circuit boards.

The IPC-2221 standard describes fundamental design requirements for the design of printed circuit boards, as well as mounting components to them and interconnecting these structures on the board. Any revision of our PCB will include these components, and thus this standard applies to our design.

4.1.3 - Power Electronic Converter Systems

IPC 62477-1:2012

This standard describes many of the components used to perform power conversion in systems not exceeding 1,000V AC or 1,500V DC, and their control, protection, monitoring, and measurement. While much of this standard is for specific systems like uninterruptible power supplies, we nonetheless expect to use simple AC-DC and DC-DC power conversion circuits in our design.

In particular, the safety guidelines outlined in this standard contribute to reducing the risk of fire, thermal, and shock hazards. This is incredibly important to the design of our device, as it is intended to be used in public, outdoor spaces and must remain safe to place in these places.

4.1.4 - Requirements for Battery Chargers

IEC 60335-2-29:2016

This standard deals with the safety of battery chargers for household and similar use. The devices referenced must not exceed 120V DC, and their rated voltage must be less than 250V. The standard details many of the common hazards of these chargers, and guidelines to ensure safety in their design.

We intend to use a battery system to provide power to our device, and must ensure that this system is not overloaded dangerously or otherwise configured in a way that is unsafe to the public. Our battery charger will be fully integrated into our design, rather than as an external one - for this reason, it must fully follow any safety guidelines to avoid fire, electrical, or chemical hazards caused by the system.

4.1.5 – Solar Photovoltaic Power Supply Systems

IEC 60364-7-712:2017

This standard outlines the proper use and design of solar power supply systems. It explains things like the ideal placement and mounting of panels, and like the rest of our power standards, provides guidelines essential for preventing fire and electrical hazards, as well as to ensure no damage occurs to our solar panel or other components powered by this subsystem.

We intend to use a solar panel to provide power to our device, particularly to charge the battery. Solar panels are complex, delicate equipment, and we want to avoid any damage to the panel itself due to misconfiguration. Conversely, we

also need to make sure that the power system supporting this panel can safely deal with the panel's output, without damaging any of its own components, as well as the rest of the device.

4.1.6 – Plastics Recycling Standards

ISO 15270:2008

This standard provides guidelines for the recycling industry as a whole for the recovery and recycling of plastic waste. It details the potential sources of plastic waste, as well as the amount of work necessary to reclaim this waste.

Our design is a part of the very beginning of the recycling chain, sorting materials and removing those which cannot be recycled. While the specifics of plastic waste recovery are not a part of this design's scope, this standard provides necessary information about the types of plastic we will need to sort, and some of their characteristics. Additionally, it provides some context for the impact this design can potentially have on this industry.

4.1.7 General Recycling Standards

When we first set out to understand more about the current recycling guidelines, it was expected to be a clear cut question with a simple answer. Little did we know how complex and conflicting many of the recycling standards and guidelines can be. From the broadest level, there is the federal government which does not directly set recycling standards but has significant influence on determining what should be recycled. There are also several government agencies, such as the United States Environmental Protection Agency (EPA) that enforce laws and acts created in the United States on a federal level such as Title 40 of the Code of Federal Regulations Part 261.4 which sets forth what items are considered hazardous waste.

Another important act that determines what is considered to be ignitable, reactive, corrosive, or toxic is the Resource Conservation and Recovery Act (RCRA). Subtitle C of the RCRA excludes wastes generated by normal household activities to be excluded as hazardous wastes. In order to be considered a household waste, the item must satisfy “(a) The waste must be generated by individuals on the premise of a temporary or permanent residence, and (b) The waste stream must be composed primarily of materials found in wastes generated by consumers in their homes.”. Even though these items are excluded as household hazardous waste, they are still regulated under Subtitle D of the RCRA as solid waste. In many states, federal guidelines for recycling and hazardous material are stringent but the states themselves can enforce more stringent recycling standards than the federal government.

Due to our project being designed, manufactured, and intended to operate initially in the state of Florida, we will strictly be considering recycling and hazardous waste guidelines for Florida only. Florida has several state government agencies for regulating how waste is handled such as the Florida Department of Environmental Protection (DEP), Florida DEP Waste

Management, Florida DEP Bureau of Petroleum Storage Systems, and Florida Department of Health - Biomedical Waste. Each of these agencies provide unique insight for determining how waste is designated and what waste can be recycled. Often, each county within a state has its own set of standards and guidelines for what can be curbside recycled. To make this even more confusing, there are also private entities such as Waste Management which may act as the primary waste collectors for a county or town in which case it is up to them to determine what can be recycled. If an item cannot be recycled via standard recycling such as plastic bags and plastic films, there are recycling groups such as PlasticFilmRecycling which can assist in pairing you with a facility or drop-off location that will be able to recycle those materials.

In Orange County, plastics and containers may be recycled as long as they are emptied and the cap is allowed to remain with the bottle. Bottles and jars can be recycled if they are emptied and the lid is removed. Aluminum, tin, and steel cans can be recycled as well if they are emptied. Flattened cardboard boxes can also be recycled. Newspapers, paper bags, mail, general paper and drink cartons can be recycled. Food waste, foam cups, plastic bags, and aluminum food pans cannot be recycled in Orange County through their curbside pick-up service. Plastic bottles and containers labeled numbers 1-5 can be recycled at Orange County Recycling facilities.

Understanding what items are able to be recycled is imperative for developing a database of materials that our machine will designate as being recyclable. Often, these recycling guidelines vary widely between counties in Florida. For example, Orange County accepts plastics numbered 1 through 5 for curbside recycling while Volusia County only accepts plastics numbers 1 and 2 which can pose significant geographical limitations and challenges that our team can overcome in the future. For this reason, our project will focus on determining the emission spectrums of plastics 1 through 5 and sorting these away from non-recyclable plastics.

4.2 - Realistic Design Constraints

This section describes the constraints the team must consider before the project is put into effect. These include personal constraints such as economic and time constraints, as well as those set by society. Finally, practical constraints are considered.

4.2.1 Economic and Time Constraints

When considering the economic and time constraints for our project, the quote "Time is money" resonates deeply within us. Although economic considerations

such as cost of materials are important, time wasted can never be made up. Our team made it our mission to never be wasteful of either given the circumstances. Economic constraints had a fairly considerable impact on the selection of parts for our design, forcing us to make some compromises along the way. Although our team would have wanted to change parts of the design if given a larger budget, we strived for the best use of our available budget of \$2,000 as possible. With the cost of industrial-grade optical sorters starting at around \$40,000 and going into the millions, sticking to our initial budget seemed like an almost impossible task. This limited us to using technology and quality of materials that may have not been desired but ultimately did not prevent us from achieving our primary engineering goals. A larger project budget would have allowed us to implement further design features that are not currently exhibited in our system. These design features would have further proven our system to be unmatched compared to current consumer waste sorting technologies.

For example, the design could have implemented features such as a small, hydraulic powered trash compactor at the bottom of the system in order to reduce downtime when emptying the waste bins. Another way we could have increased the utility of our design with a larger budget could have been through the use of a precious metals waste recovery system within our design that would have been capable of filtering out potentially valuable items that were thrown away which would increase the return on investment for our design.

Another large constraint to be considered when developing our project was time; arguably the most important constraint of all. By having limited time to design, test, and present a finished working prototype, our team had to make tough prioritizations when considering what mattered most to our design. These time constraints also made deadlines an absolute necessity in order to ensure completion of deliverables to stakeholders. By July 23th 2021, the 100-page minimum report was due followed by the final document being due on August 3rd 2021. On August 6th, 2021, a demonstration of our project will be shown to Professor Kar. After the final demonstration is successfully shown, manufacturing our entire project is to be started and completed by December 6th, 2021. Having the 4 month time period should be sufficient in order for our team to produce, troubleshoot, and correct any design flaws in our initial design.

A strong emphasis should be placed on the realistic considerations that need to be given to constraints such as time and budget. While the accuracy and capability of our design may be drastically improved with exaggerated timelines and budgets, realistic constraints must be considered in order to provide the best and most efficient use of our time and money. As noticed, there can be some large downsides with economic and time constraints but we also noticed some unique advantages as well. Having these design constraints forced our team to budget our time and money wisely, possibly more wisely than if there

were no constraints at all. We were forced to make things work because we did not have the option of expanding budget or extending time, failure was not an option. By having a limited budget, it forced us to think about the cheapest way possible to produce our design while still maintaining the key specifications needed to operate with a high degree of accuracy. A side effect of doing this is that we made our design more attractive from a financial perspective by creating unique, cost-effective solutions.

While many people may have perceived these economic and time constraints as a negative thing, our group approached these constraints open minded and think that the performance of our design is more economically efficient than if there were no constraints given. Not only did it force us to stretch the money we had in our budget, it also gave us a better understanding into the costs of manufacturing for our design and how that could be further reduced if we had more time. This experience will become valuable when assessing feasibility of designs further into future development of our product.

4.2.2 Environmental, Social, and Political Constraints

Sustainability, social awareness, and politics are not typically associated with having an influence on engineering design but our team has found these three things to be of great importance for our project. In order to stay technologically relevant, being aware of these design constraints helps us think about not what they limit us from doing but rather, potential paths of opportunity that we can explore.

Sustainability is something that, going forward, engineering companies will have to adapt to and figure out if they want to continue to thrive. Our team employed sustainable design techniques when choosing electrical components for our system such as low wattage, halogen lights as a light source for a spectrometer to use. We also used efficient, electric motors for designing the conveyor belt that will further reduce our energy consumption. The system we developed also was designed to operate in a stand-by mode, meaning that it consumes small amounts of energy when idling in between use which is not only environmentally friendly but also further increases the lifespan of the parts we use such as the light source and motor for the delivery mechanism. Another way we are able to decrease our environmental footprint is by using solar panels to partially supplement some of the power being used by our system. It would be very counterintuitive for us to develop an enhanced waste sorter to reduce the environmental impact of human error to, in turn, develop a system that further worsens the problem.

Another considerable mention of our design decisions in regards to sustainability is the selection of parts that have lower environmental impact to

produce than others. Our team chose to use components already in our possession when possible such as miscellaneous hardware. We also chose to source components like the solar panels and spectrometer from companies when possible, which we are very grateful to have the opportunity for. By borrowing items from companies, our team was able to avoid being wasteful financially and environmentally.

One of the largest constraints our group had to be aware of when designing our system was the social constraints that the users of our system are controlled by. For example; in early stages of development, our group saw some great designs from other people that involved a device that scans a person's waste and tells them if it can be recycled. While this initially appeared to be more simple and a much more appealing idea, we still struggled with the idea that there can be people that disregard the device and place their waste in whichever bin they prefer. Our team was able to avoid this by designing a system that the user had no control over the item being recycled or getting placed into a landfill, which brings us to our last topic which is political constraints. Another social constraint that will be further developed and implemented into our design is accessibility assistance for people with disabilities. We would need to ensure that people that are designated disabled are not at risk of injury when using our design.

Recycling and waste regulations are often dictated by government or waste management companies. As a result of this, future designs of our system will consider how local, regional, and state-wide recycling criteria will change the availability of certain items as recyclable. Our team does not foresee this as a major issue because it would just be a matter of updating the software's database to give more specialized recycling criteria for systems placed in different geographical areas.

4.2.3 Ethical, Health, and Safety Constraints

A major ethical concern for our group is that our system has the potential to reduce the amount of redeemable waste that would have previously been littered such as cans and bottles. While this can be perceived as a positive advantage, it can negatively affect local homeless populations and their ability to receive income from excess waste on streets or in public. By increasing the amount of waste bins available to the public, the potential for less litter will be increased. Another ethical concern that is associated with this is if future designs had a waste recovery system for things like cans and bottles that would provide an incentive for property owners that decide to use our system. Although this would benefit the owner of the property where it is being used by increasing the return on investment, it might be taking away income that somebody else needed.

Health and safety should always be of the utmost importance when engineering things that the public will be using. That is why we have considered and implemented improvements based on the safety of our users and will continue to make beneficial design changes once concerns are identified. Due to our design containing the light source, spectrometer, and any other potentially harmful radiation-emitting electronics internally in a housing that does not leak light, concern for safety in this area is ultimately very low. Even if there was light leakage in the result of an emergency or damage to the system, the light being used is a 100-Watt 2700K FEIT Electric Incandescent bulb (T3 R7) which is commonly used in regular light fixtures. In regards to sound, our device will be operating well below the OSHA limit of 85 decibels. The primary source of sound will come from the conveyor belt in action as the motors operate and the belt is moved.

Another potential health and safety concern is the potential for damaging body parts while parts of the machine are moving. This is why we designed our system to have only one partially exposed opening which will not be in open proximity to moving components such as the conveyor belt. This will reduce the risk for children getting hurt while using our machine as well as visually impaired people. Due to the fact that workers will be regularly emptying the trash from the bins contained within the machines, the system will have very noticeable and accessible power switches to prevent risk of injury from moving parts. In regards to the safety of the manufacturing of the system, we will not be using any potentially harmful components, hardware, adhesives, or anything else that will get used in the production of the system.

Safety is always at the forefront of the engineers and consumers minds when testing out new devices and machines such as ours. Not only will we take every safety measure in order to ensure the public, manufacturers, and maintenance people the highest level of safety, we also anticipate in future designs placing labeling on it stating what potential safety hazards are contained within the machine such as intensity of light, moving parts labels and more. We strive to ensure all users a positive and safe experience that will help contribute towards a more green and sustainable earth through enhanced recycling programs.

4.2.4 Manufacturing and Sustainability Constraints

To many, considering the manufacturing constraints of a design is often one of the last steps in their engineering process and can be met with a large amount of challenges. It is usually not until the integration step that these challenges are presented by technicians, the people that build the things that we design. When building them, technicians often are able to spot shortcomings in the engineer's design such as components not fitting together outside of simulations or tolerancing under different environmental conditions. At the very conception of

our design, our team began thinking of some of the most effective ways that our device could be fabricated, assembled, tested, shipped, maintained, and repaired. By designing and building the physical prototype along the way and not just simulating it, we were able to observe some challenges unique to our design that should be considered for the future manufacturability of our product. Not only will we explain how our device and its components are being sourced and assembled but also how they are being thought of in anticipation of future production.

In the early stages of development and prototyping, it is most cost effective for our team to outsource components instead of attempting to manufacture them in-house. For the electrical components such as the printed circuit board and microcontroller, we are purchasing them from a third party vendor to ensure efficiency when integrated with other components in our design. As for the conveyor belt and the motors that will power it, we are using a generic fabric as our conveyor belt even though it is not typically associated as being used for belts. The motors will be servo motors purchased from a third party vendor. As for the spectrometer, the highest degree of accuracy will be achieved by outsourcing this instead of building it in house. Spectrometer design can be an overwhelming task and at this stage, we believe it is a better use of our time and money to outsource. We do have the potential of developing a more pure light source to be used as the illumination for the spectrometer by easily sourcing bulbs more catered for our intended purpose. While the frame for our system is currently being purchased from a third party vendor, there is a good possibility that the fabrication could be done in-house. Although this would be a large capital investment in the beginning, it would offer a large reduction in the cost to manufacture the system resulting in a high return on investment.

Typical waste bins can be exposed to a variety of environmental elements such as extreme heat, extreme cold, high winds, rain, snow, dust, and many more. Over time, these environmental elements that the waste bins encounter will chip away at its lifetime as a product. Not only do waste bins encounter weather, they also have moisture and liquids inside of them from the trash that gets thrown out. In our design, our initial objective is to make the internal components of this system as waterproof as possible in order to maximize the sustainability of our system and minimize the amount of repairs that are needed. This will involve putting the spectrometer in a casing so that only the probe of the fiber will be exposed to the conveyor belt which minimizes the risk for damage. In future designs, we would like to research potential fiber probes that are made for environments such as ours.

Although the outside of our design is not currently weatherproof, we have many ideas as to how we can further improve upon this in the future. For example, we

could outfit the frame in a reprocessed plastic such as recycled HDPE sheets. Weatherproofing the external frame of our design may seem very expensive, it appears to be a necessary evil as long as the system has potential for outside use.

5 - Project Hardware and Software Design Details

This section describes the thought process behind the hardware and software of CAWSS. It features a design schematics, design matrix and associated analysis, and detailed descriptions of the subsystems. It also features breadboard schematics and descriptions of software development.

5.1 - Initial Design Architectures and Related Diagrams

The following images were the initial design concepts decided upon by the CAWSS team. Significant changes have been made since these early sketches were made - sensor position, optical component position, and trash insertion are just a few repositioned portions. A more in-depth analysis will be presented in the final design summary of 5.11.

5.1.1 - Design Mock-Up

The first image below shows a SolidWorks rendering of the CAWSS from an outside view, based entirely on the rough original concept sketches created during our first group meetings (shown in figures 25 and 26, earlier). This mockup shows an overall idea of what the device could look like from outside, including a solar panel and the conveyor belt delivery system. This second diagram provides a more detailed layout of the CAWSS's internals, centered around the conveyor belt and flapper delivery systems we currently plan to use.



Figure 26. CAWSS CAD Rendering

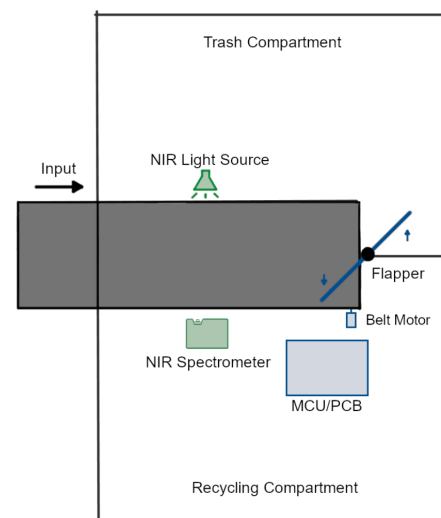

Figure 27. Internal CAWSS Diagram

5.2 Decision Matrix

Table 17 below was utilized by the CAWSS team when deciding on the pros and cons of building vs borrowing a spectrometer. Ultimately the cost of building a spectrometer was outweighed by borrowing a spectrometer from Ocean Optics. This is discussed more thoroughly in section 8.2.

Criteria	Build NIR Spectrometer	Borrow OceanOptics NIR Spectrometer
Resolution	0	+
Cost to build	-	+
Electrical Power Usage	0	0
Hazardous Emissions	0	0
Durability	-	+
ROI Potential	+	-
Ease of Use	-	+
Time taken to implement	-	0
Alignment to strategy	+	+
Variability	-	0
Sum of Pros	2	5
Sum of Cons	5	1
Sum of Neutrals	3	4
Total	- 3	4

+	Pro
0	Average
-	Con

Table 17. Decision Matrix

5.3 Analysis of Decision Matrix

Overall, the decision matrix that we constructed provided useful and valuable insight that can help us further investigate which route to continue down. When considering making our own Near-Infrared Spectrometer, several advantages present themselves. First, it could have a high return on investment in the future if production was scaled up to manufacture a higher volume of our design. Not only would we avoid purchasing costly spectrometers from third party vendors, our team could also make improvements specific to our application such as increased resolution in the part of the electromagnetic spectrum we are analyzing. Some of the disadvantages are that the initial capital investment to develop our own NIR spectrometer would be quite high when compared to renting or borrowing one. Also, our design is most likely not as durable as some of our competitors.

When considering borrowing an Ocean Optics NIR spectrometer, the biggest advantage is that it requires no initial investment as we would be borrowing it for free. This would allow us to save on the overall cost of the design and potentially use that money to further improve other components. Another advantage is that the Ocean Optics NIR spectrometer is relatively user friendly and easy to implement for the application that it will be needed for. While both of these options present distinct advantages and disadvantages, we will ultimately choose the option that presents itself as the most beneficial for the long term feasibility of our concept and design.

5.4 - Delivery Subsystem

Once we understood the theory behind the different methods that are available to differentiate plastics, our next objective as a team was to determine the most effective and feasible system design to be used to accomplish our goal. The most obvious design decision that we had to make was whether the trash should be gravity fed down a chute versus whether the trash should be moved through the system using a conveyor belt. Both of these options provided us with apparent advantages and disadvantages that will be discussed in greater detail.

The gravity chute concept is a very appealing, less complex way of letting trash enter the system with the end goal of reaching its final destination. The use of gravity fed systems in the optical sorting industry is widespread but much more commonly it can be seen being used in conjunction with a conveyor belt and gravity chute as seen above. Typically, the trash gets fed onto the belt through a hopper in which it then gets line-scanned where it will be either read directly through spectroscopy or hyperspectral imaging. After this, the trash continues to move down the belt until the conveyor belt abruptly ends and trash is sent over the side of the machine in a free fall. It is during this free fall that a pneumatic air

jet will blow the object to either the waste side or the recycling side which concludes the identification process.

Initially, the idea of using a gravity chute seemed like a very simple way to solve a complex problem. Specifically, we are referring to a gravity chute as an angled slide for conveying things to a lower level, like the one shown above. The more we considered it under the budget and time constraints we are dealing with, the less appealing it became. To begin, the optical method of identifying the waste is the largest limiting factor for our design team. Although the use of hyperspectral imaging is proving itself to be one of the most effective and versatile optical identification methods in the waste-sorting industry, this often comes with a hefty price tag as well as more complex optical designs. In order to create a line scan, many companies use a rotating octagonal mirror to reflect the light from the source onto the conveyor belt. This is a very effective method of creating a line scan but instantly, we began to wonder whether a line scan was even necessary. Sure, it is effective at dealing with high volumes of plastics at high processing rates but we determined that high volumes and high processing rates weren't exactly the design parameters we were looking at. Post-consumer waste entering a trash bin typically does not enter at a fast pace nor does the volume of trash that commercial optical sorters deal with either. When considering the optics, money, software, and time required to develop an effective hyperspectral imaging system for waste identification, it was determined that this was not in our cards.

On the same topic of gravity chute systems for optical sorting, it is also effective to use fiber probes to identify waste instead of using hyperspectral imaging. Some of the larger limitations of using a fiber probe and spectrometer to identify waste is the cost of the fiber and spectrometer combination, the optical limitations of putting light into a fiber, and possible waste splatter onto the core of the fiber. After realizing that the spectrometer and fiber seemed to be the more feasible route, we began to inquire about loaning spectrometers from OceanInsight and we were fortunate enough to be able to obtain a Flame-NIR spectrometer that was capable of detecting wavelengths in the range that was needed for plastic identification.

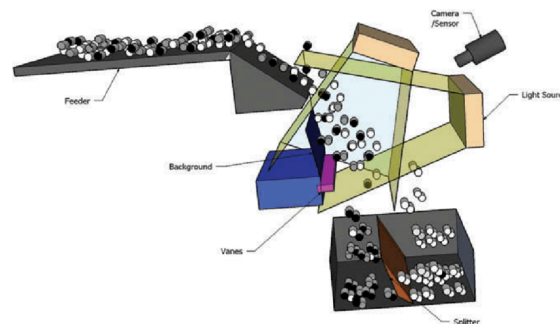

Figure 28. 45 Degree Optical Sorter (permission pending)

Another major consideration with the gravity chute system is the mechanical delivery of waste from the top of the chute to the bottom. To begin, the entire chute system would have to be 5 feet or less in order to ensure that people of all sizes can put waste into the top of the system. This restricts the size of our internal design significantly, reducing the volume of the trash containers that we can use as well as making it more difficult to get a spectra of the object because of the short amount of time it would take to obtain a spectra. We considered putting a stop powered by a motor that would stick up perpendicular to the chute so that the trash would stop at that point and a reading could be obtained and then once complete, go flush against the chute to let the trash continue to travel downwards. This made us consider the following: If we are going to use a motor to create a flap to stop the trash, how much easier is this than using a conveyor belt? At least with the conveyor belt, we have the potential of taking multiple emission spectrums of the object as it passes on the conveyor belt and averaging them to get a more accurate spectrum since we have the capability of stopping the movement of the object whenever needed. A conveyor belt provides more flexibility than a flap belt for obtaining emission spectrums which was a high priority for our team.

Our team also considered things that could impede the flow of the objects sliding down the chute such as liquids or debris that result from other objects. This could significantly impact the performance of the system if waste traffic is increased from an event or during peak times. If the liquid was sticky, it would have the potential of catching objects and causing a building of trash in the chute. Another mechanical consideration for chute is that all of the gravity chute optical sorters that we have seen use a pneumatic jet, either one or two on the sides of the chute, to control the direction that the object is heading in. This not only would increase the cost of the system but also could be very difficult to use when shooting air at smaller objects or low weight objects such as napkins or plastic bags. It could also be very tricky timing the air jet puff to be in sync with the software analyzing the emission spectrums of the plastics. The compressor that would be used to power the pneumatic air jet could also cause major health and safety issues due to the high noise levels that they typically operate at.

An additional gravity chute consideration that we think is worthy of mention is a 90 degree free fall chute. Trash would enter the top of the chute and instead of the object sliding down a sloped surface and being stopped to be scanned, the object would free fall from the top of the system and be scanned mid-air. After the object is scanned mid-air, the software would then analyze the emission spectrum of the object while it is in flight and obtain a destination for it. While the object is continuing to fall after being analyzed, the pneumatic air jets would then obtain a decision from the software and put the object in its correct destination. The largest concern with this design is that the software and spectrometer may not have sufficient processing time to make a design before

the object reaches the air jet. This would also be problematic when analyzing objects that are very heavy, as they would fall at a faster velocity than an object with less weight. It would also require much more powerful air jets than the other chute design because a large percentage of air would be wasted if the area was open rather than having at least one side closed in like with the angled chute solution.

When considering the limitations that both of these delivery mechanisms would place on our concept, it became apparent that a conveyor belt would be the most feasible solution to achieve our primary engineering goals. By using a conveyor belt, we could immediately remove the pneumatic air jets out of the equation which would allow us to spend valuable time enhancing the analysis software instead of wasting time with the delivery mechanism. It also will be cheaper and more environmentally friendly to purchase things that can be repurposed for the conveyor belt rather than having to purchase the air jets, compressor, and tubing for the other option. Another important consideration with the conveyor belt is, like mentioned above, the conveyor belt gives us the freedom to stop and start the belt with ease so that we can better ensure the accuracy of our results by potentially averaging multiple spectral readings from the object instead of getting just one reading. This can prove useful when analyzing an object that is not of a homogeneous material such as a bottle with a label or a napkin with food waste on it. Also, we have the potential to control the speed of the objects flowing down the conveyor whereas with the gravity chute object, you are restricted to the laws of gravity unless you interrupt the motion of the object. By controlling the speed of the objects, we can have better control with lighter weight objects.

The ultimately agreed upon waste delivery mechanism includes an input chute at roughly 45 degrees. This will be in the form of a cylindrical tube. This tube must be large enough to accept all normally-sized waste and narrow enough to orient waste of all shapes and sizes so that they are delivered to the conveyor lengthwise. Uniform trash orientation is important to the spectral data collected; ideally all trash will pass before the spectrometer lengthwise so that the angle of light reflection is similar for all subjects. This will also guarantee that the trash approaching the flapper sorting mechanism will all be oriented in a manner that will not cause jams or otherwise impede the flow of waste to bins.

5.5 - Optical Component Subsystem

After our team decided on going with the conveyor belt delivery mechanism, we then shifted our efforts into the positioning of the components. Certain components such as the fiber probe and light source have a significant performance impact on our design and should be heavily tested. Although these components were chosen with the specifications needed to obtain wavelengths

from 900-1700 nanometers, that is only under the assumption that they are being used in their controlled operating environment which is most likely a lab. Due to the differences in the environments that these will be used in, it is crucial to determine the ideal angles, placement, intensities, and many other parameters that will be determined to ensure optimal efficiency.

To begin with, let us start with the easiest components to consider and move onto some of the more challenging ones. As long as the fiber we purchase has sufficient length, the position of the spectrometer does not matter that much because the light will enter through the fiber and propagate down the fiber into the entrance slit of the spectrometer. This means that the position of the spectrometer can be anywhere and there will not be much of a change in the emission spectrum of the light. We do not anticipate using enough fiber to have attenuation in the signal and also do not anticipate putting the fiber in any awkward positions like tight corners or twistings that could cause bend losses. The most important consideration with the position of the spectrometer is preventing it from water damage that could result from waste traveling down the hopper and conveyor belt causing liquids to splatter if left uncapped. This can easily be solved by protecting the spectrometer in a water-resistant housing. This housing can be made out of cheap materials and should not interfere with our financial and time limitations.

The next and more challenging components to consider are the light source and the fiber optic probe. These are lumped together in our considerations because they are directly related to each other; the position of the light source in relation to the fiber probe will determine how much light enters the fiber as well as how much saturation can occur in the spectrometer. There are multiple ways these two components are configured in commercial optical sortings and all of them should be considered in relation to our primary engineering goals.

A common position of the fiber probe is being hung or suspended over the conveyor belt so that the end of the probe is directly over the objects that pass underneath. This can bring some physical challenges to the waste on the conveyor belt and their height in relation to the height of the probe being suspended. When considering this, it is apparent that the overhead position of the probe becomes limited by the height of the garbage. The solution to this problem would be imposing a dimension limitation for objects that can enter the system which then creates usability and functionality issues. Not only this but if the user disregards the dimension limitations for the system, the fiber probe is at risk of being contaminated or damaged in the process. Another potential solution to this issue would be making the height of the fiber being suspended much higher than the maximum height that an object entering the system can be. This can cause issues related to channeling light into the end of the fiber,

potentially minimizing the amount of light available to reach the core. It would be necessary to angle the source, whether positioned overhead or on the side, to direct as much light as possible into the fiber in order to be able to obtain the smallest amount of light possible to create a spectrum. An additional limitation that could affect this design as well would be if any additional lenses were needed for collecting and directing light into the fiber. This would be a very complicated position to accurately implement lenses with because the design would be vertical, not horizontal, which would cause us to be working against gravity.

A second consideration for the position of the fiber and light source is to have the fiber probe on one side of the conveyor belt with the light source on the exact opposite side of the conveyor belt, directing light through the object into the fiber on the other side. While this initially appeared to be the go-to way of positioning the fiber and light source, limitations of this design appeared rather quickly when discussing this aloud. To begin with, this light and fiber configuration would depend on the amount of light that transmits through the material in order to obtain an emission spectrum of the object. If this object is opaque or very dark, a large percentage of the light would be absorbed in the material which would decrease the effectiveness of directing light into the fiber. Also, if the object had liquid still in it this would further decrease the effectiveness of obtaining a spectrum because it could diverge or converge depending on the substance. Another consideration is that pure water is absorbed between 480-700 nanometers which does not concern our design. What does concern our design is that glucose, or sugar, is absorbed at 1420-1480 nm and 1630-1730 nm as well. This is concerning because we will be obtaining IR emission spectrums between 900-1700 nm and the absorbance glucose commonly found in sugary drinks could cause significant noise with our signal and prevent us from accurately identifying the plastic.

5.6 - Conveyor Subsystem

The conveyor subsystem consists of two sensors, the sorting flapper, and the conveyor belt. It will control the delivery and processing of the incoming waste materials, in addition to controlling the turn on/turn off of the optical system. The two main non-functionality considerations taken into account during the design process were weight and cost.

5.6.1 - Conveyor Belt

The conveyor will be constructed from treadmill material - this may be acquired for little to no cost via free or nearly free giveaways on Craigslist or Facebook Marketplace. This material will be cut down to size as needed, and will either be run on the pre-existing treadmill architecture or on a self-constructed conveyor pulley system. The conveyor belt must be long enough to carry waste from the

location of acceptance to the bins while providing enough space for spectral analysis to be accomplished. The current size requirement for the belt is expected to be roughly 3 feet.

5.6.2 - Sensor Placement

Two different sensor placements are being considered. These will be used to gauge the approximate location of the incoming waste so that spectral analysis will occur when intended, and so that the system isn't in a constant "on" state. The first option places both sensors a good deal before the spectrometer. These will be used to calculate the size of the object via the speed of the conveyor belt in centimeters per hour. The amount of time it takes for the object to cross both sensors will be multiplied by the speed of the belt, and will yield the size of the object. This will then be used to calculate the turn-on time of the optical system. This configuration should circumnavigate unwanted interference from the light source, but would complicate the programming required for proper execution.

The additional sensor placement is simpler, but offers difficulties in the way of ambient light interference. One sensor would be placed before the spectrometer, and one after. Once the first sensor becomes blocked, the system would turn on. The system would turn off after both the first and second sensors are blocked and unblocked. The difficulties of this situation lie in the photodiode nature of the currently applied sensors. The spectral output of the lamp might be so great that the photodiode's own signal is overwhelmed. This would create a situation in which the photodiodes never read a signal in which they are blocked, therefore causing them not to function. Combatting this issue would prove difficult, as the output of the halogen light covers the majority of the light spectrum. Placing the sensors on the side of the conveyor belt opposite from the optical setup might combat the issue. This is the preferred sensor configuration, but requires in-person testing to verify effectiveness.

5.6.3 - Flapper

The flapper component is meant to sort the waste into appropriate bins after correct identification. It will utilize a servo motor to move the flapper from one side to the other. The flapper must not directly touch the conveyor, but must be close enough to it to successfully guide practically-sized samples into the appropriate bin. It must be tall enough that bottles cannot be pushed over the flapper before sorting is accomplished or while being guided into the correct bin. The sorting decision for the flapper must be made some time before the waste reaches the flapper, which necessitates a reasonable amount of space between the flapper and the optical system. The flapper will be constructed from wood or plastic, and will be mounted on a wooden stick. These components must be sturdy enough that they will not break or become loose over time.

5.7 - Breadboard Test and Schematics

The first breadboard test consists of testing the relay circuit. The relay circuit is designed to be triggered by the microprocessor after setting a HIGH signal on a GPIO pin that enables the transistor. This action will in turn energize the relay solenoid and actuate the relay switch. To achieve this in the breadboard, the microprocessor is replaced by an Arduino development board. The positive terminal of a 12V battery is connected to one side of the relay coil and the normally open terminal of the relay. The negative terminal of the battery is attached to the common terminal of the relay and the emitter terminal. By attaching the opposite side of the relay coil to the collector terminal, the relay switch will actuate when the Arduino energizes the base terminal. This is because the transistor is enabled and allows current to flow from the battery, through the relay coil, and through the transistor to meet the negative battery terminal.

If the theory is not flawed, a bulb will light up when connected to the common and normally open terminals of the relay if the GPIO pin is set to HIGH. The circuit was then replicated on a breadboard and the results are pictured below:

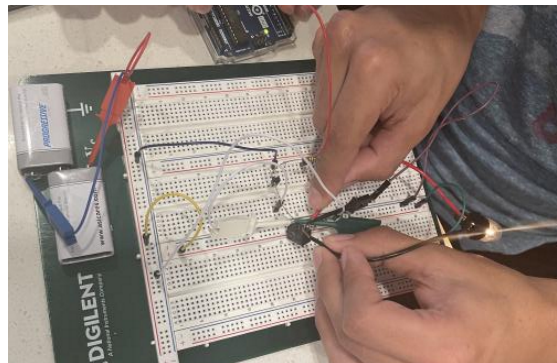

Figure 29. Relay Breadboard Test

Next, the DC to DC converters can be tested for stability in the breadboard. This is performed by powering both units with a 12V battery and attaching a low resistance resistor to the output. This will cause the LDOs to function at a lower efficiency and increase the current output which causes heat buildup. The regulators should be tested at this condition for an extended period of time to ensure heat buildup can be tolerated without damaging the units or create voltage instability at the output.

The LDOs can also be tested with high resistance resistors to evaluate the regulator's stability at a low current output. This behavior is not harmful for the regulators but might cause instability to the microprocessor and spectrometer driver, and a minimum current for stability can be identified from this test. If instability is observed at low output currents for the LM1084 regulator, then the component can be swapped for a model with a reduced maximum rated current

such as an LM1085. A linear voltage regulator with a lower max current rating will provide more stability at low current output. The same applies for the LM1086 unit which powers the MSP430 microprocessor.

The last test that can be performed on the breadboard entails the MSP430 microprocessor, which must be programmed and tested before being soldered to the PCB. Once the microprocessor is programmed, it will be placed on the breadboard and tested for functionality. The microprocessor will be receiving inputs from the spectrometer driver and should actuate the relays accordingly, which confirms a successful implementation of power source, relay design, and programming. Once this test is completed, the system will be installed in the PCB.

5.8 - Software Architecture

The flowchart below describes the high-level sequence of actions our software will direct our device to perform. Each individual block is color-coded; blue represents tasks performed by the MCU, and green represents spectral analysis tasks performed by the SBC and FlameNIR.

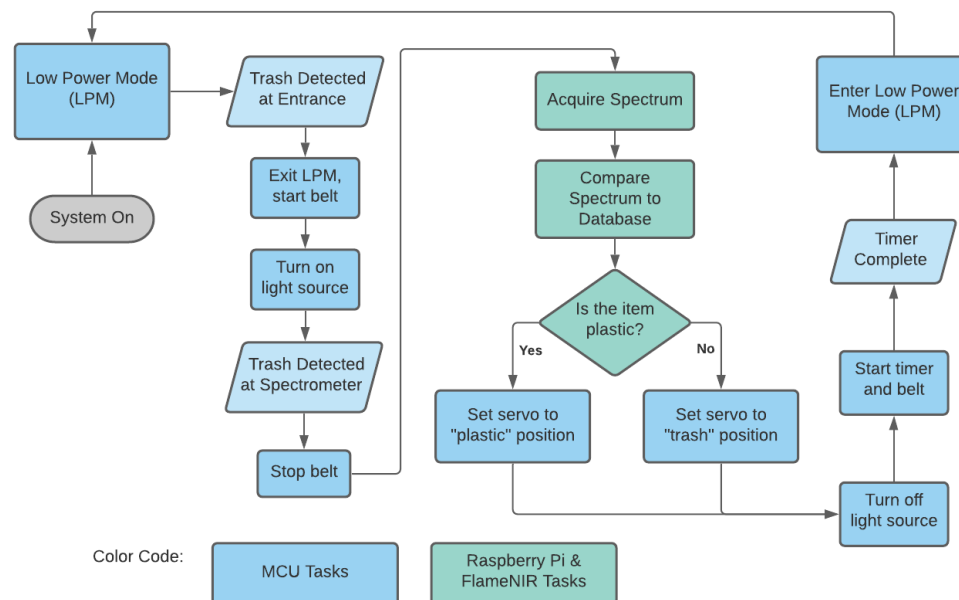

Figure 30. Generalized Software Architecture Flowchart

5.8.1 MCU Software Architecture

For the sake of prototyping, our software architecture assumes several conditions that we currently believe will be true in our final design. We assume we will be using the ATmega2560 MCU referenced in section 3.3.6; as such, all code for this component is written in the C++ programming language, with the

standard Arduino and AVR microcontroller libraries included. We also assume we are using the conveyor belt system discussed in section 5.6 with a motor which operates via a simple binary toggle, that sensors 1 and 2 will operate as binary, active low inputs, and that simply stopping the belt when an item arrives at sensor 2 will position it correctly for spectral analysis. Most of this software's functionality will be contained in Interrupt Service Routines (ISRs) that execute when a specific input is received, with its main function used to initialize and prepare these ISRs.

Main Function and Power-Saving Mode Discussion

When the MCU starts up, it will initialize all variables, timers, and pins needed for proper operation. All outputs will be set to their “off” states manually to ensure that the motor and lamp are not running until the device is fully ready and an object is detected at the entry sensor (referred to as sensor_1 in the code). Then, it will enable the first ISR (shown in the next subsection), before entering the lowest power state the ATmega2560 supports, “Power-down” mode.

Sleep Mode	Active Clock Domains					Oscillators		Wake-up Sources						
	clk _{CPU}	clk _{FLASH}	clk _{IO}	clk _{ADC}	clk _{ASY}	Main Clock Source Enabled	Timer Osc Enabled	INT7:0 and Pin Change	TWI Address Match	Timer2	SPM/EEPROM Ready	ADC	WDT Interrupt	Other I/O
Idle			X	X	X	X	X ⁽²⁾	X	X	X	X	X	X	X
ADCNRM				X	X	X	X ⁽²⁾	X ⁽³⁾	X	X ⁽²⁾	X	X	X	
Power-down								X ⁽³⁾	X				X	
Power-save					X		X ⁽²⁾	X ⁽³⁾	X	X			X	
Standby ⁽¹⁾						X		X ⁽³⁾	X				X	
Extended Standby					X ⁽²⁾	X	X ⁽²⁾	X ⁽³⁾	X	X			X	

Figure 31. ATmega2560 Power State Characteristics

In this state, all clock sources on the chip are fully disabled. However, there are still several ways to wake the processor to its normal, running state. In particular, a properly configured Interrupt Service Routine that triggers when a pin's state changes is able to wake the processor. Although the chip's datasheet states that the pin must maintain its changed state for some time to exit Power-down mode, this is still ideal for our use case, as we only need the MCU to exit this state when an item is fully stationary at the entrance. Once an input is verified and execution starts, the MCU will instead use the “Idle” mode between interrupt events until an item has been fully sorted, to avoid any unnecessary delays incurred when exiting these lower-power states.

Sensor 1 ISR

This simple ISR is enabled when the program starts (as shown above), and executes when a rising-edge pulse is received from sensor 1. As explained in several other sections of this paper, this sensor will be placed at the device's entrance to detect when a user provides trash for sorting.

On entering the ISR, the program first verifies that trash is present. If not, we assume that the sensor has registered a false positive for some reason, and simply return to a low-power state. Otherwise, the ISR will disable its own interrupt event so that the sequence of actions is not stopped by another user's trash, and continue executing. It will then turn on the spectrometer's lamp and start the conveyor motor, enabling the second sensor's ISR before completing execution and exiting to the "Idle" mode.

Sensor 2 ISR

This ISR is triggered by the second, internal sensor of the device. A pulse from this sensor is interpreted as confirmation that an item is positioned correctly for spectral analysis. Despite being located in a much more controlled environment, this input will still be validated via the same methods as Sensor 1 to check for any false positives.

Once the input is verified, the ISR will disable its own interrupt event and fully stop the conveyor belt. It will then send a rising-edge pulse, notifying the software running on the system's Raspberry Pi to collect and analyze spectral data from the FlameNIR (as discussed in the Raspberry Pi Software Architecture subsection). The next ISR is then enabled so that the Pi can wake the processor, and the program returns to the "Idle" mode again.

Analysis Result ISR

This final ISR is triggered by a rising-edge pulse sent by the Raspberry Pi, which does not need to be verified. When the ISR is entered, the program will disable this interrupt, and check the second pin connected to the Pi. A logical HIGH on this pin indicates that the item has been identified as recyclable, and a logical LOW indicates it is not. The servo controlling the "flapper" in our design will turn according to this input, directing the item where it belongs.

The program will then turn on the motor, turn off the spectrometer's lamp, and wait for a predetermined time interval; long enough for the item to be directed to its compartment. Once this time has passed, the motor will be turned off, and the Sensor 1 ISR will be re-enabled before returning to the original "Power-down" mode, where the MCU will stay until the next item is placed at the entrance.

5.8.2 Raspberry Pi Software Architecture

The software running on our Raspberry Pi will be responsible for communicating with the FlameNIR spectrometer and analyzing spectral data received from it. As briefly discussed in section 3.3.7, communication with the FlameNIR is made possible through the open source python-seabreeze module. This module provides a Python wrapper for the functionality of Ocean Optics' original SeaBreeze C/C++ library, which is available for public use under the same MIT license.

All code for the system's Raspberry Pi will be written in Python. This allows us to easily use python-seabreeze with the Flame, as well as the plethora of excellent open-source Python modules for statistical and spectral analysis. In particular, we have already implemented functions from the widely-used scipy statistical analysis library, matplotlib functions to display our data as we prototype, and various numpy tools to contain and manipulate spectral data. It also provides us the ability to run our software on any system which can run a Python 3 environment, making prototyping much more convenient.

The following screenshot of our preliminary software was taken on the Pi we expect to use in our final design. Here, the software is being used in a debugging mode, which allows us to select a previously captured spectrum as the "current" spectrum (shown in blue) as if it were just received from the FlameNIR. This allows us to develop the software even without direct access to the FlameNIR at all times. The terminal to the left shows the level of detail offered by our algorithm for each individual comparison, with matches over the threshold (described in the following section) highlighted in yellow. The most likely match is then plotted in the same graphical window, in red.

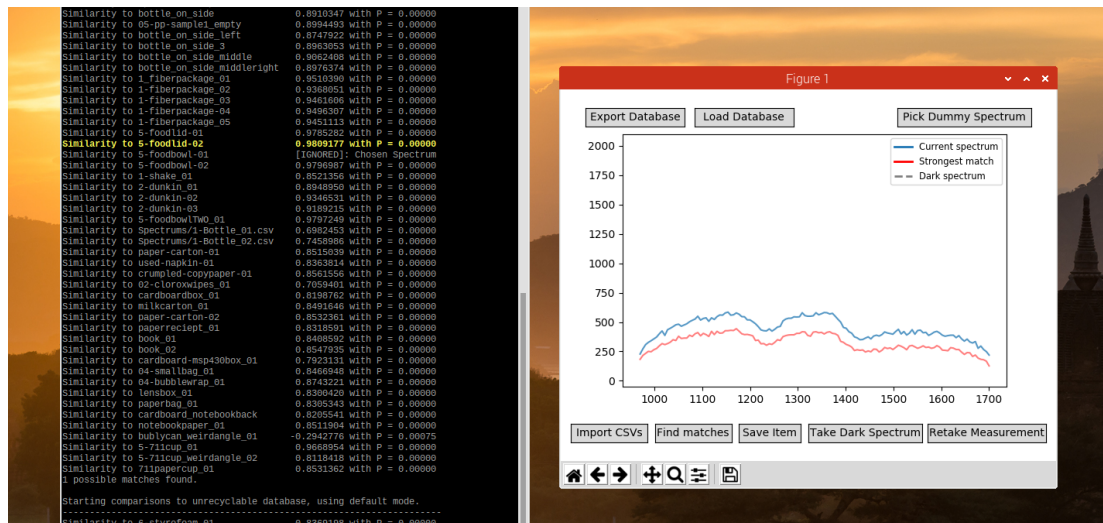

Figure 32. Preliminary analysis software in manual/debug mode

While this user interface will not be accessible in this manner in the final design, it is an essential part of our prototyping process, allowing manual control over the FlameNIR and extremely granular data for us to analyze as we iterate on our algorithm.

The analysis that will be done by this software is mathematically complex, but the sequence of tasks is short and simple. After startup and establishing a connection to the FlameNIR, the program waits to receive a start signal. Once the signal is received, it commands the FlameNIR to capture a spectrum using a predefined integration time and saves this spectrum to a numpy array. This operation takes less than 1/5 of a second. The array is manipulated and compared to our database of known recyclables, as discussed in the next section. The result of this comparison will ultimately be a binary value that will then be sent to the MCU as described earlier: a “1” shows that the software identified the material as recyclable, a “0” shows that it was not. The program then resumes waiting for its next start signal.

Discussion of Spectral Analysis

Spectral analysis is largely based on established statistical methods for comparing large datasets. The best method we found for our needs while researching was the use of Pearson’s Correlation Coefficient. This coefficient represents the degree of similarity between two linear datasets of the same size. A perfect match results in a coefficient equal to 1, with more dissimilar datasets resulting in values closer to 0. The scipy library provides this method in the `scipy.stats.pearsonr(x, y)` function, where `x` and `y` are the two spectra being compared. The equation returns both the coefficient and a P-value we can interpret as this method’s “confidence” in a result.

This Correlation Coefficient is an ideal method of spectral comparison primarily because it takes some steps to alleviate baseline artifacts in a dataset. It is similar to finding the Euclidean Distance between two datasets, but mean-centers spectra before they are multiplied. The following equation is used to find the Pearson Correlation Coefficient:

$$\text{Correlation Coefficient} = \frac{(x - \bar{x})(y - \bar{y})}{\sqrt{\sum (x - \bar{x})^2 \sum (y - \bar{y})^2}}$$

Our analysis algorithm generally produces satisfactory results with a value of 0.98 set as the threshold for a “matching” pearson coefficient. This value was found partially through experimentation; however, later in our development process we also found a manual for the Essential FTIR Spectroscopy Toolbox [44], which also uses correlation coefficients to compare spectra, claiming that “Generally, a result of 0.98 or better is a good match...”. The manual also states

that taking the first derivative of a spectrum may be desirable when there are broad, slowly-varying background features. If we find that our database produces too many matches, we may apply this change; quick visual analysis of our data indeed shows that NIR spectroscopy produces spectra with large, similar regions, potentially skewing our results and producing false positives.

As this function can only compare one pair of datasets at a time, we will iterate through a database of known recyclables, comparing each to the spectrum being currently analyzed. On receiving a start pulse, the `spectrometer.intensities()` function is called, which triggers the FlameNIR to take a measurement and provide it to the Pi. This result is saved in a numpy array, which is passed as the “x” parameter to the function. The “y” parameter will correspond to an array holding a spectrum from the current position in the database as the program iterates through it. This routine will loop until all spectra have been checked, indicating whether a likely match was found in a boolean variable. As shown in the screenshot earlier, the routine also reports on the exact similarity for each spectrum in the database, and indicates which comparison resulted in the highest similarity. Showing this data is not a requirement of our final design (which only needs a binary result, given to the MCU), but we may choose to add some way to display it to users if we have time after the required parts of our design are complete.

Spectrum Database

We will be maintaining our own database of known recyclables and common false-positives for comparison using this method. Existing databases of materials in the FlameNIR’s wavelength range may exist, but they are likely to be large and contain an excess of additional materials beyond what our device is expected to encounter or identify. Our use case is specific and simple; we need to correctly identify materials that are commonly recyclable. Any material unknown to the database should be assumed to be trash, as the range of recyclable materials is small. We are thus unlikely to incur any consequences from overfitting our dataset to these common materials.

Since some non-recyclable materials (such as #6 plastic, or Styrofoam) closely match recyclable ones, we will also maintain a smaller database of common “false-positive” non-recyclables. If a spectrum is found to match any of these items, the software will make the pessimistic assumption that the spectrum is not recyclable. This is preferable to being too optimistic, and sending potentially non-recyclable items to a recycling plant.

Currently, each database is contained in a single Python dictionary object, saved and loaded to the Pi’s storage as necessary using the `Pickle` object serialization library. This provides convenient access to smaller datasets like

ours, as we do not need the additional features of a more purpose-built database, and it allows us to use simple existing Python objects for data storage rather than converting between several data formats.

5.9 - Power Subsystem

The CAWSS is composed of three separate power systems: the battery recharge subsystem, the relay powering subsystem, and the PCB power subsystem. The battery recharge system is composed of a 100W solar panel that recharges one of the two batteries installed in the machine. This system is put in place to alleviate the discharging of the main battery, as this component will be powering the high wattage lightning and DC motors. The battery replenishment will be interfaced by a charging module that regulates the temperature and current output of the battery, as continuous use of the machine might raise the battery's temperature to the territory where simultaneous recharging and power extraction is not recommended.

The charging module will be programmed to resume replenishment once the machine enters stand-by mode, or the battery temperature is reduced due to lower power demand. It is important to recall that batteries have a lower maximum temperature threshold for charging versus discharging state, so the charging driver must be set to the lower temperature threshold which is commonly around 100 degrees Fahrenheit for charging state. The CAWSS system does not have any element that might dissipate large amounts of current, since the motors and lightning will not be powered simultaneously and therefore the current limits of the battery are less of a consideration.

Moving on, the main battery will power the lightning and motors of the machine by way of the second subsystem of the machine: the relay subsystem. The relay array in the PCB is categorized as a power subsystem given it uses a different power source than the other elements in the PCB. The main battery is attached to the main battery connector in the PCB, and only delivers main battery voltage to the switching terminals of the relays. When the microcontroller signals for a relay to be energized, the main battery will supply the motor or lightning load through the relay circuit embedded in the PCB. Given all bulbs and motors are connected to the PCB relays, swapping the main battery only requires disconnection from a single connector. The main purpose of the two-battery design is to prevent a discharged main battery from shutting off or disturbing the other electronic components in the PCB. Additionally, the spectroscopy equipment operating from the other elements in the PCB has a retail value of \$8000 and, as a result, decoupling PCB traces encompassing high current is desirable.

The third power subsystem in the CAWSS machine uses a secondary battery to power the electronics in the PCB, the spectrometer driver, and the spectrometer unit. This secondary 12-Volt battery energizes these components via two independent voltage regulators, which are both attached to the secondary battery connector. Two independent DC-DC converters are required since the microprocessor chip utilizes 3.3V while the spectrometer driver uses 5V; given the sensitive nature of a spectrometer to noise, separating the 3.3V circuit from the 5V circuit using two independent regulators was the most appropriate alternative. Both LM1084-5 and LM1085-3 regulators are accompanied by the input and output capacitors recommended for stability. The spectrometer driver is attached to the regulator through a USB A connector, while the microprocessor uses the PCB traces to obtain power from the regulator.

5.10 - Housing Subsystem

The housing required for the CAWSS is critical for stability and spectrum accuracy. It must absorb incoming infrared light while still providing the strength to support roof-mounted solar panels. It must be large enough to house the optical system, and must include optical mounting components.

5.10.1 - CAWSS Housing

The CAWSS housing will be constructed on top of a skeleton material that is vibration resistant in an effort to combat the extraneous movement created by the motors and conveyer belt. The housing will be designed and constructed after all other subsystems have been tested and assembled. This will be done in an effort to minimize size and weight of the system while still leaving enough space for the design to function properly.

A dual-compartment system is being considered. The separation of the waste-conveyor system would allow the delicate electrical components to be protected from any accidental splashes or other damage from external sources. All passive system components would be sectioned behind a panel, and access would be made possible through a rear-opening access panel. An alternative configuration would be the placement of passive components in an external housing attached to the side of the CAWSS. All passive components would communicate with the active components inside of the box via wire and fiber connections. The same protection can only be given to the fiber and the lens if IR-transmissive material is used. This would prove problematic, as any material would certainly alter the system's ray paths and could make spectrum collection impossible. A solution to this issue is to build a box around the fiber, and mount the lens pinhole-style into the front of the box. Transmissive material would not be required - in fact, light-dissipation around the fiber would reduce any ambient noise from the system. This would serve to protect the fiber from any debris or liquids, and would reduce the amount of maintenance needed. The lens itself

would require occasional manual attention to assure its cleanliness and therefore its effectiveness. The frequency of this maintenance would be reduced by proper space between the lens and the incoming waste. Small panels with IR-reflecting material will be placed around the sensors in an effort to prevent cross-talk between the sensors and the IR light source.

5.10.2 - Optical Suspension

The housing subsystem includes a suspension system for lens and fiber and component placement and protection. The lens itself will be contained by a lens holder system. This system will be 3D printed in an effort to reduce costs - a lens holder for a 3-inch lens can be more than \$50, and thus a home-made solution can offer significant savings. This lens holder will feature a top and bottom component in order to lock the lens in place. After the lens is secured, metal rods will be fed through holes on either side of the holder. This will then be fixed in place by a locking mechanism.

The lens holder will be preceded by a chemistry clamp holder. The adjustable alligator-like clamp will serve to hold the fiber in place while not putting undue stress on the delicate fiber. This will also be mounted to a metal rod, and will be adjusted for ideal alignment with the focal point of the lens.

5.11 - Summary of Design

Finalized images of the CAWSS system are pictured in figures _ and _. Significant changes have been made since the figures presented in 5.1. Inserted trash now enters the system through a top-based rounded chute that serves to guide incoming trash into an analysis-friendly orientation. The CAWSS box has been elongated to roughly 6 feet in order to accommodate the conveyer, flapper, and solar panel. The solar panel remains on top of the CAWSS box in order to best collect incident light, and the flapper and conveyer positions remain the same.

The internal configuration of the CAWSS has changed significantly since the initial drawing was made. The NIR source is now on the same side as the collecting lens and fiber. It's set at an angle to the optical components so as to shine off of different surfaces in a consistent direction. Sensors will now be positioned to the left and right of the optical system in order to dictate when spectrums will be taken. Components such as the PCB and the spectrometer will be stored underneath the conveyor system for a more compact design.

6- Project Prototype Construction and Coding

This section details how the code and PCB were developed. The schematics of the PCB are discussed, along with the reasoning behind parts selection. The PCB vendor and the final PCB prototype diagrams are presented in an effort to be prepared for PCB ordering. The final coding plan is also presented.

6.1 - Integrated Schematics

To begin designing the circuits for the CAWSS, we will first focus on the relay system that will be operated by the microprocessor. The microprocessor will receive a determination from the spectrometer driver which will indicate if the material is recyclable or not. The brain of the CAWSS will then actuate the corresponding components to sort the material appropriately. To achieve this, a relay system must be employed as the microprocessor cannot energize high-power components such as motors and bulbs. Driving a relay from a microprocessor will then require a transistor and a power source, which can be the same source powering the high-power components. Given the CAWSS machine will use a 12V battery system, a 12V relay will be employed.

The 12V relay requires a 12V differential across its coil to operate satisfactorily. Providing more voltage across the coil will exceed the coil's power rating and might damage the relay, while providing less voltage might result in the coil failing to actuate the internal switch. Once 12V is supplied to the coil on the positive terminal, the negative terminal can be attached to the collector of an NPN transistor. Since a microprocessor GPIO pin typically operates close to its Vcc (generally greater than 2.5V), triggering HIGH on the pin will provide more than enough voltage at the base to enable the transistor. Additionally, GPIO current should not commonly exceed 30 or 40 milliamps of current draw and an inline resistor may be required. When the transistor is enabled, current will flow from the collector to ground, closing the circuit for the relay coil to be energized.

This circuit allows the microprocessor to trigger a relay where the high-power elements can be attached and energized on demand. A 12-Volt relay usually has an internal resistance of 600 to 800 Ohms and, as a result, the current entering the transistor should not exceed 20mA which is within the rated current of a low power transistor. Last, it is important to place a flyback diode parallel to the relay's coil with the cathode attached to the battery. The force that opposes current change in a coil, or counter-electromotive force, constitutes a danger when an inductor circuit is suddenly opened. The generated counter-EMF when the circuit is opened creates a very large voltage spike, as current flow suddenly changes and the generated counter-EMF from this change does not have a path to flow. An analogy to this effect would be that of an impact drill, where a sudden stop of the impact element creates enormous torque only for a very brief period of time.

This voltage build-up in the coil of a small 12V relay (such as one rated for 30A) can achieve voltages of 120V or 200V for up to 5 microseconds, potentially damaging other components since high voltage can give rise to current flow across unintended paths. A flyback diode allows for the counter-EMF to have a closed circuit back to the other terminal of the coil, eliminating the voltage accumulation that occurs with an open coil terminal.

The circuit will then be constructed as follows:

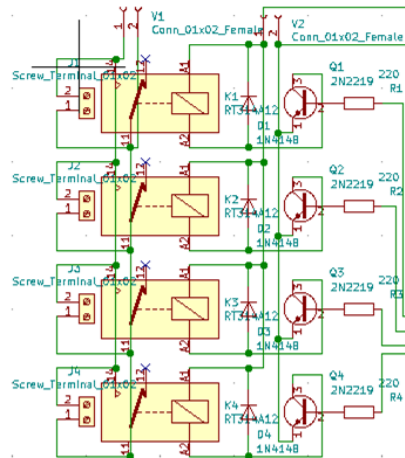

Figure 33. Relay Circuit Schematic

Moving on, the spectrometer driver circuit will be designed as this system must operate satisfactorily before providing a signal to the microprocessor. The spectrometer driver consists of an SBC (single board computer) required to interpret the digital output of the spectrometer. In other words, the spectrometer unit does not have an analog output and therefore requires a driver to process the data, which takes significant effort to implement in a microprocessor without an operating system. As a result, the SBC can consume up to 2.5A at full load from Vcc in addition to the 500mA consumption of the spectrometer (which is also powered from the SBC's 5V Vcc). As a result, a 12V-DC to 5V-DC linear voltage converter (LDO necessary over switching regulator for noise suppression) rated for more than 3A is required for this circuit. A Texas instruments LM1084TI-5 will be implemented to power these two components, since it has a maximum current output rating of 5.5A and is suited for high voltage differentials. Attaching the LDO to the 12V terminal and the USB-A connector will be carried out as follows:

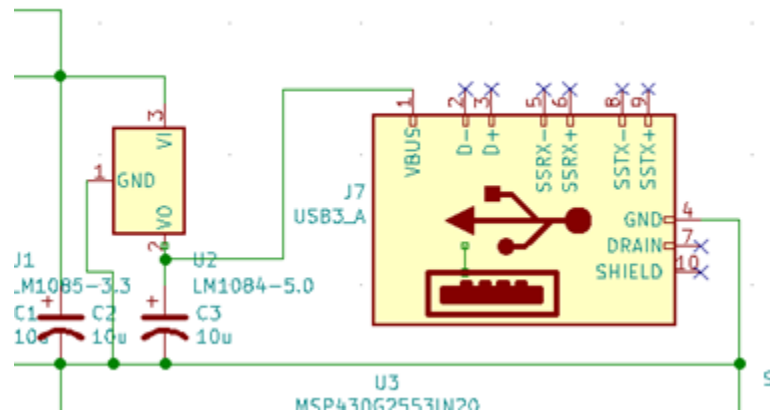

Figure 34. Spectrometer Driver Power Schematic

From the schematic, we can see two tantalum capacitors in parallel with VI and VO as required in the specification sheet for stability. Moving on, the same process will be repeated using a LM1086 for the microprocessor. Given we are already familiar with the LM family of linear regulators, we will use a 3.3V version of the LM1086 which is rated for a maximum output current of 1.5A. Since the MSP430 microprocessor uses 3.3V for Vcc, the 220 Ohm resistor inline with the GPIO yields a safe current of 15mA. Attaching the second LDO to the 12V terminal and the microprocessor will be carried out as follows:

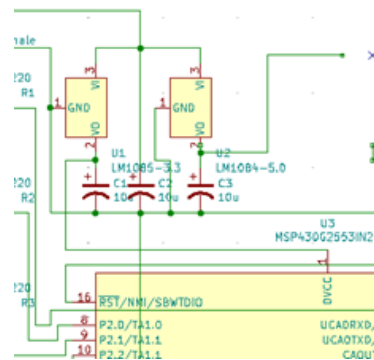

Figure 35. Microprocessor Power Schematic

Moving on, we can proceed to interface the MSP430 with the base of the transistors and pin headers. GPIO pins 7 through 10 will be used to enable the transistors as these pins can be directly routed using PCB traces. The remaining pins will be routed with PCB traces to pin headers, which will be then utilized for UART communication with the spectrometer driver, IR sensor interfacing, and JTAG programming. Finally, the reset pin will have a PCB trace leading to a grounded button. In this fashion, the microprocessor can be reset to a determined state on demand. The microprocessor interconnection look as follows:

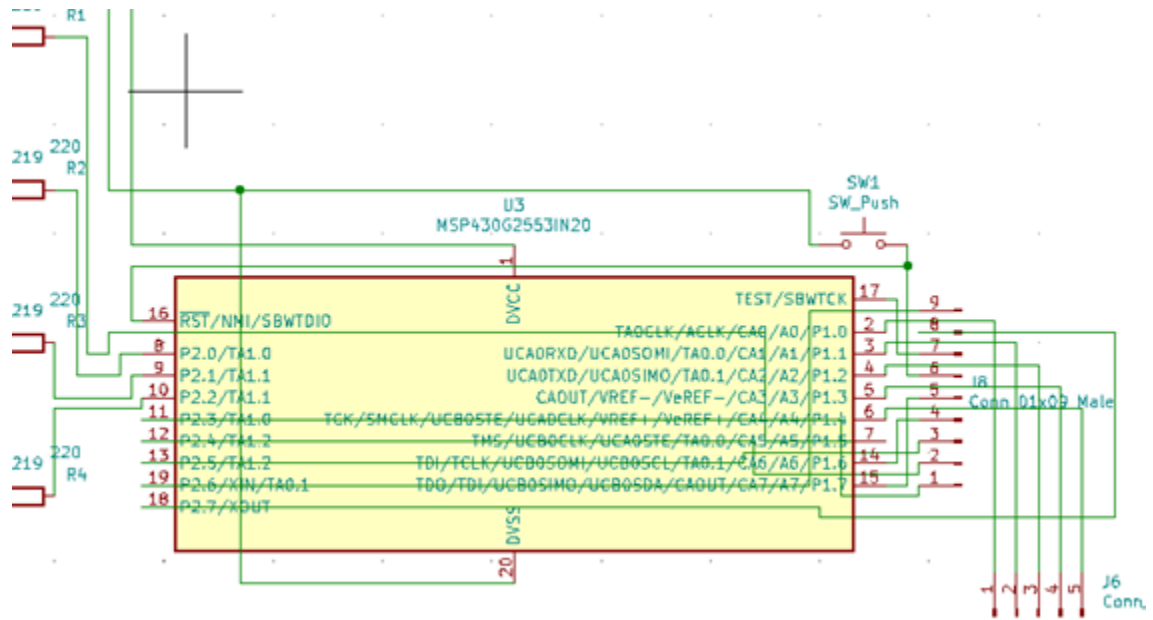

Figure 36. Microprocessor Interconnection Schematic

The finalized schematic for PCB design is pictured below:

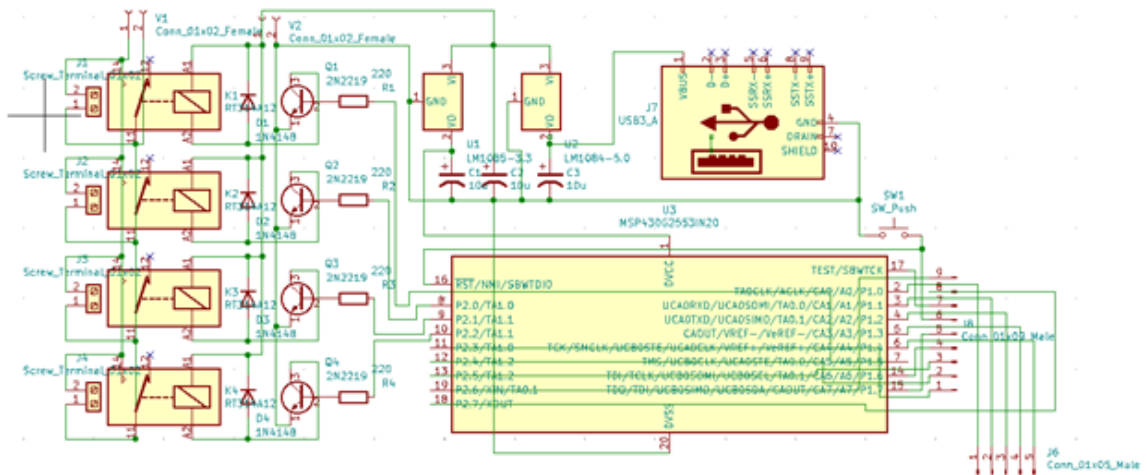

Figure 37. Integrated Circuit Schematic

6.2 - PCB Vendor and Assembly

The PCB can be manufactured by well-known online vendors such as JLC PCB and PCB Way, or by domestic vendors like OSH Park. Domestic vendors provide better customer support and design approval, potentially at a higher cost. On the other hand, international vendors provide a streamlined ordering system with a wide range of specification selection and limited customer support. These international options are better suited for intermediate-level designers that require more technical designs, while domestic options are a better alternative for entry-level designers that need a simple design with manufacturer input.

For instance, PCB Way offers 5 different materials each with different temperature ratings, multiple widths of minimum track spacing, over 7 different surface finishes, and more importantly, multiple options for copper weight. PCB designs that employ traces with high current usually require a higher copper weight to offset temperature, however, this option is often not offered by vendors. JLC PCB has fewer options for PCB material, PCB thickness, PCB finish, and only two options for copper weight. However, their PCB boards are considerably cheaper than an equivalent board from PCB Way. Additionally, their 4 business-day shipping service to the USA is almost 50% more economical and the interface is easier to navigate overall.

Finally, OSH Park offers a single option for material, finish, thickness, and copper weight. Nonetheless, the FR4 material comes with a desirable ENIG finish, TG-175 temperature rating, and RoHS compliance among other desirable specifications. Additionally, there is a special option to increase the copper weight and thickness of the PCB at the cost of a long turn time.

Although PCB Way and JLC PCB offer PCB assembly, the circuit board will be assembled by the team to save on production costs. For this purpose, the PCB was designed with primarily through hole components that are easier to solder compared to surface mount elements. A few surface mount components such as the GPIO resistors were still employed in the PCB design to avoid interference with a trace in the bottom layer. It is important to recall that some traces in the PCB will operate with currents up to 9A and consequently a higher copper weight and trace width might be required, limiting the choices for PCB manufacturing.

6.3 - PCB Design

The printed circuit board will be designed using KiCad design suite. KiCad is an open-source software for electronic design automation developed since the early 90's with capabilities comparable to that of the Eagle design suite. KiCad provides 3D viewing of the PCB board, a vast footprint library, and has a simplified interface compared to Eagle. The determination of using KiCad suite over Autodesk Eagle (other than Autodesk no longer providing student licenses to UCF other than through UCFapps) comes mostly from the fact that KiCad is a free product, and it inherently has stronger community documentation and support.

To begin, a sketch of the PCB circuit is drawn by hand. This provides a map of the elements that must be interconnected to each other while also listing the parts to be added in the KiCad schematic editor. Once the parts are uploaded to the schematic, the KiCad software will display all ports from each component giving the user a visualization of other connections required for a part to work properly. For instance, the KiCad schematic editor indicates one of the relays we are using for PCB prototyping has a normally open connection pin that needs to be accounted for.

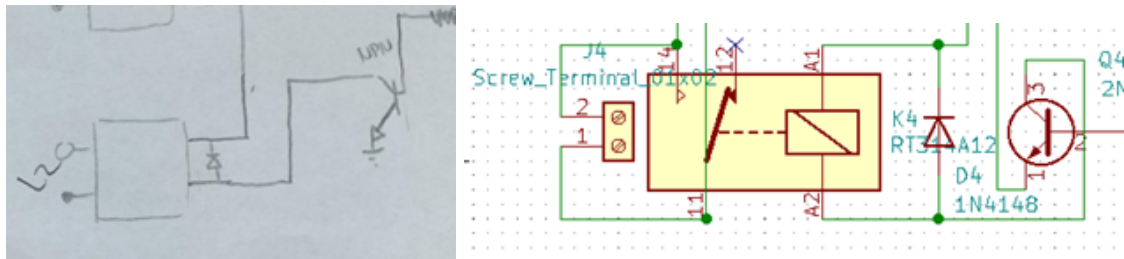

Figure 38. Hand Drawing Vs. Eeschema Part

After all elements are properly interconnected in the schematic, the Assign PCB Footprints tool must be launched. KiCad provides footprints for a wide range of electronic components, however, a generic symbol can be used as a placeholder if a component is not found in the library. After the schematic is ready to be rendered into its physical form, these placeholders must be linked to a footprint in the footprint editor. For example, resistors in the schematic are linked to a specific package in the footprint tool or imported CAD footprints from a manufacturer can also be attached to a symbol via this tool. Texas Instruments provides KiCad footprints for most of its products in Ultra Librarian. Once this step is performed the schematic drawing is then finalized, and a netlist file can be generated for the PCB layout tool.

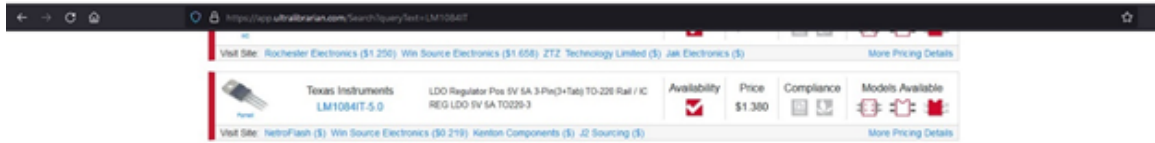

Figure 39. Ultra Librarian Footprint

The PCB layout editor is the tool where the printed circuit board is arranged. When the netlist file is loaded, the PCB editor will display all the elements with accurate physical dimensions. If the PCB has a physical size constraint, the limits of the PCB board can be traced prior to the arrangement of elements and routing of the conducting copper. Given the CAWSS machine has large dimensions, our PCB does not have a size constraint and the elements will be arranged beforehand.

The elements in the PCB layout editor are displayed with a trace to guide the user on which elements must be interconnected according to the schematic, reducing the number of times the designer must refer to the schematic. When arranging the components, it is important to adhere to good practices such as refraining from scheming 90-degree traces, parallel traces on top and bottom, holes too close to a trace, and insufficient trace width. For our PCB design, all these guidelines were conserved. To achieve this, the auto-route option in the software was not utilized and thus the PCB was arranged and traced by hand.

When designing the PCB, it is important to adjust the location of the elements to allow for a practical design of the circuit board while respecting good practices. In our case, the microcontroller had to be displaced away from the linear voltage regulator that powers it to allow a proper placement of the input and output capacitors required for stability. This shift in component placement enabled the traces to remain apart from each other without any steep bends. Although a track width of at least 50 mils was used for high current traces, having extra space between tracks and components allows a further increase in width if thermal management requires it.

Given the PCB was designed with maximum use of the two layers in mind, most traces do not have a neighboring track on the same layer. As a result, the minimum trace spacing of 0.13mm per IPC-2221 is followed. The trace width was also calculated to IPC-2221 specification, using the formulas provided by the association which are displayed below:

$$Area[mils^2] = \frac{Current[amperes]}{(0.048 \cdot TRise[centigrade]^{0.44})^{1/0.725}}$$

$$Width[mils] = \frac{Area[mils^2]}{1.378 \cdot CuWeight[oz/ft^2]}$$

spectrometer driver and the PCB will not handle any signal communication among its components. As a result, a copper fill for grounding and noise suppression is not required.

Last, a USB female socket will be embedded in the PCB to provide connection to the FlameNIR. Given these sockets have a metal casing, two through-vias were implemented to transfer the traces to the bottom layer and thus avoiding traces to travel directly below the metal casing.

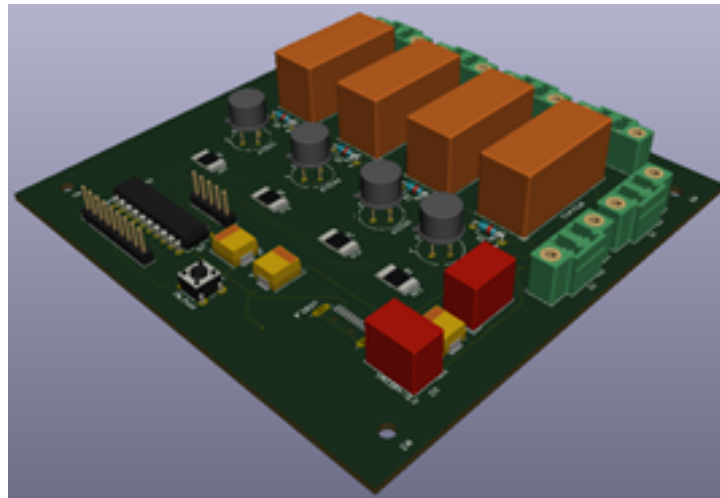

Figure 39. PCB Design 3D View

6.4 - Final Coding Plan

A large portion of the software design for this project will be completed well in advance of building the physical system that the software will operate, as we will be presenting a demonstration of our progress designing the optical and analysis systems of our design before the end of Senior Design 1. This is one of the reasons we planned our software design to be split across two distinct components as discussed in section 5.8; we are able to focus on the more critical spectral analysis part of the design on the Raspberry Pi without needing to depend on the MCU's sequence of actions being perfected first.

We have planned to primarily focus on designing the software that will run on the Raspberry Pi. As discussed further in section 5.8.2, utilizing the open source SeaBreeze API enables the Pi to perform spectral analysis as competently as any commercial solution available, and provides us with the flexibility to use this analysis to perform any action we want. We plan to continue developing our analytical methods with a temporary graphical user interface that will be disabled once we are ready to implement the analysis in our completed design. This interface graphs the current spectrum, provides manual control over data

collection and analysis triggers, and crucially provides the tools needed to save spectra to our database of materials.

Once we feel prepared to move on to implementing more of our overall device design, especially the conveyor belt and additional sensors, we plan to also complete the software that will run on our MCU. This software is relatively simple, and discussed in-depth in section 5.8.1. We plan to implement a system which remains in the MCU's lowest available power state whenever possible, only exiting this state when a user's trash is detected at the device entrance. This is handled by an interrupt, set up to properly wake the MCU from sleep when this event occurs. All major tasks done by the MCU are handled similarly, ensuring that tasks occur immediately when triggered and allowing the use of low-power states between all tasks.

Testing of these different software components is described further in sections 7.2 and 7.3 - each device's software will be tested separately to ensure they operate as expected independently before combining their functionality.

7- Project Prototype Testing Plan

This section details how hardware and software testing was or will be performed. This testing is outlined in an effort to assure that testing is thorough and that all components are covered. It is hoped that any possible scenarios that could cause complications or critical failure come to light during the processes. This will allow the CAWSS team to remedy these before the end of Senior Design 2 and emerge with a complete product.

7.1 Hardware Specific Testing

Hardware testing is an important stage for our team in the design process for our system. It provides accurate validation that these components do not just work in theory but that they also work in practical application which is undoubtedly the most important factor in our project. Many hardware specific testing procedures were developed with the intention of validating components for their role in distinguishing waste based on its spectral features.

7.1.1 Spectrometer Testing

Objective: The objective of testing the spectrometer with the spectrometer's software is to ensure the accuracy of the spectrometer for its intended purpose in our project. This test will require the use of the OceanInsight NIR Flame Spectrometer, SMA-to-SMA 905 Fiber Patch Cable, Micro-USB Cable, tape, a coffee mug, and a PC. The PC being used will act as the power supply to the NIR Flame spectrometer and the micro-USB will be acting as the communication link between the spectrometer and the spectrometer driver. We will be conducting the spectrometer testing in an application called OceanView distributed by OceanOptics.

Environment: The laboratory environment that this specific testing will be conducted at is a team member's apartment.

Procedure: In order to accurately test the hardware and software, the following procedure will provide simple steps.

1. Uncap the SMA-to-SMA fiber patch cable and visually check the end of the fiber patch cable's core to see if any visible debris can be observed. If there is visible debris observed, use isopropyl alcohol and a lens wipe to clean the end of the fiber until no remaining debris is there.
2. Screw the non-protruding end of the fiber patch cable into the fiber port of the spectrometer while keeping the other end of the fiber capped. Do not yet plug the USB into the computer.

3. Open OceanView by OceanInsight and click the “Search Devices” button to open the scan for the spectrometer. At this point, plug the spectrometer into the computer and click the “Rescan” button until the spectrometer appears. Click “Confirm” and close out of the box. Ensure that the red and green lights are emitting light on the spectrometer.
4. Observe background noise moving around on the spectrum’s plot. This is a clear indication that the spectrometer is receiving power and it is effectively communicating with the drivers. The spectrometer should be operating on the standard settings.
5. Place the coffee mug in an upside down position on the table and tape the end of the fiber to the bottom of the coffee mug. Ensure that you do not tape over the core. This is to prevent variations from movements with the measurement.
6. Click the lightbulb icon to take the dark spectrum with the fiber capped. At this point, the spectrometer’s noise should have decreased significantly to an intensity count of plus or minus 50. Then uncap the fiber and take the light spectrum.
7. Hold different objects at a distance of less than 10 centimeters away from the end of the fiber and see if the spectrum varies. If the spectrum is changing, this is a further indication that the spectrometer is taking accurate readings and the dark and light spectrums were taken correctly. If the spectrum is not changing, there is most likely an error when the dark and light spectrum was taken.

Conclusion: Some very interesting observations were made when testing the efficacy of our OceanInsight Flame NIR spectrometer. Most importantly, we observed distinct changes in the spectrum of different materials which is extremely important for coming close to our goal of differentiating objects based on their spectrum. This observation proves our theory of observing materials based on their near-infrared spectrums can provide valuable data that can aid us in better understanding what post-consumer materials are recyclable and what others are not. Also, we gained a better understanding for how the dark and light spectrum is taken and mathematically, what is happening. This allowed us to be able to develop our own dark and light spectrum procedures for our custom built software that will be used as the primary driver and data analysis software for our project.

7.1.2 Light Source Testing

Objective: The objective of testing the various light sources that we purchased was to ensure that we are using the light source that: does not over-saturate the spectrometer, bright enough across the wavelength range that is needed, and is stable over testing. This is extremely important because without the correct light source being chosen for our design, we will not be capable of accurately reading spectrums of various waste materials. The bulbs we will be using are a 7-Watt 3000K FEIT Electric Incandescent bulb (Wedge), a 60-Watt Sylvania Incandescent Ceiling-Fan Bulb (A15), a 100-Watt 2700K FEIT Electric Incandescent bulb (T3 R7), and a 250-Watt 3000K Incandescent bulb (T3 R7). We will be using a T5 socket, an A15 socket, and an industrial work lamp for housing the various light sources.

Environment: The laboratory environment that this specific testing will be conducted at is a team member's apartment. The laboratory environment will have lights completely off and blinds closed to ensure minimal light interference.

Procedure: In order to accurately choose the correct light source and to obtain optimal positioning of the fiber relative to source, the following procedure provides steps to achieve those goals.

1. Set up the spectrometer and software as explained in the previous testing procedure. Take the dark spectrum with the end of the fiber capped by clicking on the dark lightbulb icon.
2. Starting with the 7-Watt wedge bulb, position it at 90 degrees, the bulb should be facing the wall directly at this point. Position the fiber also at 90 degrees, making it parallel with the source. Place an object that has peaks in the 900-1700 nanometer range such as a water bottle in front of the light and fiber.
3. By taking a continuous spectrum through the software, one can easily observe the real time effects of moving the fiber and light-source closer together or further apart as well as at different angles relative to each other.
4. Observe at which angles and distances the spectrometer is the most saturated and record these results. These results will be crucial in determining which position for the light source and spectrometer is best, irrespective of the different types of light sources.
5. Working from the 7-Watt wedge bulb up to the 250-Watt T3 R7 bulb, observe which light sources appear to give the sharpest peaks without oversaturating the spectrometer.

Conclusion: It was easy to conclude that the 7-Watt light source was not bright enough to create a distinguishable spectrum, regardless of the position of the light and fiber. While the 60-Watt Sylvania Incandescent Ceiling-Fan Bulb was bright enough to create a readable spectrum, it appeared that the 100-Watt 2700K FEIT Electric Incandescent bulb created much sharper peaks on the emission spectrum. We believe that this could have been due to the reflective metal behind the bulb in the work lamp housing, causing a larger percentage of light to be emitted than without the housing. Also, the shape of the T3 R7 bulb itself seems to have some effect on how the light gets distributed, potentially focusing the light in a horizontally oval shape rather than a large spherical shape. Lastly, the 250-Watt 3000K Incandescent bulb appeared to be much too intense which caused the spectrometer to become oversaturated very easily. The emission spectrum peaks with the 250-Watt bulb also appeared to be a bit more broad.

In terms of the angle and positioning of the fiber, it was observed that the height of the fiber core should be about the same height as the light source. When the height of the fiber and light source were at different heights, the amount of light entering the fiber appeared to be significantly less than when at the same heights. Regarding the angle of the light relative to the fiber, it was observed that the light being at 90 degrees facing the wall and the fiber being about 45 degrees, towards the source while also facing the object appeared to be the best configuration of the two. Due to the housing of the work lamp only emitting light at roughly 30-150 degrees, any angle outside of this range is not illuminated. Therefore, the fiber at a minimum must be at least 30 degrees offset from the light source if the light source and fiber are level with each other.

In terms of the distance between the light source and fiber, 15 centimeters appeared to be the point at which the maximum amount of light would enter the fiber core without over-saturating the spectrometer. Lastly, the distance of the objects away from the fiber and light source is a crucial design parameter when considering what the width of the conveyor belt should be. Although it is possible to have a lower power light source and to view objects closer to the fiber, this can cause issues such as contamination from the waste onto the probe. We found that the 100-Watt 2700K FEIT Electric Incandescent bulb was the sweet spot for not over-saturating the spectrometer but also being able to get accurate emission spectrums of our objects at a reasonable distance away. It was observed that any distance between 10 and 30 centimeters was sufficient with the 100-Watt light source to obtain an accurate, consistent, spectral reading.

7.1.3 Spectral Analysis Testing

Objective: The idea behind the spectral analysis testing is also the fundamental goal that our system aims to achieve; to be able to analyze the spectrum of an object and compare it against a spectrum database of other known recyclable objects. This is the primary method that our system will be differentiating recyclable from non-recyclable objects. This spectral analysis testing will consist of three phases. The first phase will be setting up the test equipment such as the spectrometer and light source in the same way that was mentioned in the previous test methods. The second phase will be recording the dark spectrum, the light spectrum, and also configuring the spectrum database to add the spectrum of the known recyclable material. The third phase will be executing the spectral analysis and observing the results. We will be using the Ocean Insight Flame NIR Spectrometer in conjunction with the SMA-to-SMA 905 Fiber Patch Cable, a 100-Watt 2700K FEIT Electric Incandescent bulb (T3 R7) housed in a work lamp, the software spectragrpyh (an open-sourced spectroscopy application), a ring stand with a fiber clamp, and a black backboard for absorbance of excess light.

Environment: The laboratory environment that this specific testing will be conducted at is a team member's apartment. The laboratory environment will have lights completely off and blinds closed to ensure minimal light interference.

Procedure: To ensure that our spectrometer is capable of matching objects to a library of spectrums via spectral similarity analysis.

1. Set up the spectrometer, light source, and lens as explained in the previous experiments and start up the custom spectrometer software being tested.
2. Take a spectrum of two different objects that are known to be manufactured from the same material. For example, two plastic bottles that are both made from Polyethylene terephthalate glycol, otherwise known as PET-G. The type of plastic can be confirmed by observing the number on the bottom of the bottle or material.
3. Acquire a 5-times averaged spectrum for one of the objects and save that object as the reference spectrum to compare the other object, or sample spectrum, against.
4. Once the spectrum is acquired and saved as a reference, take the other object and get a spectrum for this one as well. Save this spectrum as the sample spectrum and execute the analysis for the two.
5. Once the analysis is started, this should end with a percentage of similarity between the spectrums of the two objects. If the percentage is

above 98%, the objects are considered to be the same for the purpose of recycling.

Conclusion: There are some background elements not mentioned in the above procedure that went into the design of the software being used to acquire the spectrum and then analyze them for spectral similarity. To start, the program uses a commonly used method of comparing spectrums known as Pearson Coefficient Analysis, or PCA. This method is explained in the Software Architecture section as well. It compares two datasets, representing their similarity to each other as a number from 0 to 1, with 1 only occurring if the exact same spectrum is compared. In order to be able to use this method, it is necessary to have minimal baseline fluctuations when obtaining your reading. Due to our readings in the final design being taken in a confined environment, with external light sources removed, many inaccuracies in our results will be corrected when the readings are taken from inside our enclosed system rather than an open testing area. Although using Pearson Coefficient Analysis did yield results that differed by about plus or minus 0.02 for the same material, it did not give any false positives under our chosen standard of a 0.98 threshold. A result above this threshold will be accepted as sufficiently “similar” to a known recyclable.

Another thing to consider is that in order to be able to get this program to effectively compare random samples of waste against a library of spectrums taken of known recyclables, we first have to actually compile that spectrum of known recyclables. This is an intensive process that requires collection of many materials that are known to be recyclable such as plastics, aluminum, tin, paper, and many more. This will make the process of analyzing the samples much easier because once the reference spectrums are saved, it will only be necessary to obtain the sample spectrum and the analysis process will be automated. Once this library of spectrums is compiled, the process for analyzing spectral similarity will be greatly improved and the speed at which our system is able to process samples will be vastly improved.

We will also be designing a small database (relative to the first) of non-recyclables that are known to produce false positive matches to our recyclable database. If an item is found to match any item in this database (using the same 0.98 threshold), it will be assumed non-recyclable regardless of whether a recyclable spectrum closely matches it. For example, PS-6 plastic (commonly known as Styrofoam) is not recyclable, but produces a spectrum that closely matches other plastic types. For the purposes of this product, it is preferable to be pessimistic about the recyclability of an item, rather than to send non-recyclable materials to a recycling facility.

7.1.4 Lens Testing

Objective: The lens purchased must be tested with the fiber and spectrometer to make sure that it meets the light collecting needs of the system. Brief simulations were done to determine the lens shape needed for correct guidance of the light, and the numerical aperture of the lens was determined. The purpose of this testing is to make sure the lens selected through these procedures yields the expected results. The lens selected is the Thorlabs N-BK7 Plano-Convex Lens (LA1002). This test will require the use of the OceanInsight NIR Flame Spectrometer, SMA-to-SMA 905 Fiber Patch Cable, N-BK7 lens, 3D printed lens holder, 100 W halogen bulb, bulb mounting, chemistry clamp stand, stackable books of varying thickness, and light-absorbing back surface.

Environment: The laboratory environment for this test is a team member's apartment. Lights are to be turned off and blinds are to be lowered for minimal light interference. A non-reflective backing will be used behind samples measured in an effort to minimize spectral interference.

Procedure: The following procedure outlines how the selected lens was tested for the required characteristics.

1. Set up the spectrometer and software as explained in section 7.1.1
2. Take the dark spectrum with the end of the fiber capped by clicking on the dark lightbulb icon.
3. Position the 100 W halogen bulb at a 70 degree angle with the sample's surface normal. Position the lens holder and the fiber at a 70 degree angle in the opposite direction as the halogen bulb.
4. Move the lens until the lens is roughly a foot from the sample - this is the distance at which the lens is expected to be placed in the final product.
5. Move the fiber so that it is exactly at the lens's focal length - 150 mm. Use the books to adjust the height of the lens as needed.
6. Place an object that has peaks in the 900-1700 nanometer range such as a water bottle in front of the light and fiber. Optimize the fiber and lens's location in reference to the sample and each other.
7. Observe and capture the spectrum with the lens in place. Remove the lens from the holder (keep holder in place to preserve location) and capture the spectrum without the lens in place. This allows us to confirm that the lens is either helping or harming the collected spectrum.
8. Collect spectrums of various samples to confirm the ability of the lens to collect accurate spectrums from items not at the lens's focal length.

Conclusion: The lens chosen yielded the predicted results. It enhanced the system's light-collection abilities and ultimately enhanced the spectrometer's ability to yield recognizable and distinct spectra. The addition of the lens added an unforeseen consequence - when the light source is too bright and the lens too close to the object too much light is gathered and the spectrometer becomes saturated.

7.1.5 Sensor Testing

Objective: The infrared sensor system must be tested for positioning, ability to function in tandem with an IR lightsource, and sensitivity. This test will require the use of the 100 W halogen bulb, bulb mounting, light-absorbing black surface, bottle samples, and IR sensors.

Environment: The laboratory environment for this test is a team member's apartment. Lights are to be turned off and blinds are to be lowered for minimal light interference. A non-reflective backing will be used behind samples measured in an effort to minimize spectral interference.

Procedure: The following procedure outlines how the sensor will be tested for the objectives previously outlined.

1. Set up light and sample bottles as described in section 7.1.3.
2. Connect the photodiode to a multimeter in order to obtain a voltage reading when light is incident upon the sensor. No external light source is needed since an LED is attached to the photodiode unit.
3. Verify sensor doesn't erroneously detect an object in its path when no object is present.
4. Test that the sensor can see an object placed in front of it. After a signal is attained, move the bottle until the sensor can no longer "see" the object. This will determine if the chosen sensor will be able to work at the range needed for it to fulfill its role in the project.
5. Place the sensor at the measured maximum range. Turn on the halogen lamp while keeping a bottle in front of the sensor. Does the sensor still "see" the bottle?
6. Do this step if the previous step was successful. Turn off the lamp and place the sensor next to the lamp. Turn on the lamp. Can the sensor still see the bottle? If the answer is yes, two possible sensor configurations are available for implementation.

Conclusion: This testing will yield the best possible sensor configuration for our project. Other sensor options will be tested if neither of the above configurations work for our NIR source. If no light sensors work, other options will be tested. There is a chance this will be the case, as our light outputs a large amount of visible light in addition to the NIR light being utilized.

7.1.6 Conveyor Belt Testing

Objective: The conveyor built by our team must meet the basic functionality of a conveyor. The objective of this test is to confirm that the conveyor belt is exhibiting the functionality desired by our team and to assess the speed at which we wish the belt to move. The speed assessment will be made through spectrometer analysis and operation. This test will require the use of the 100 W halogen bulb, bulb mounting, light-absorbing black surface, bottle samples, and conveyor belt assembly.

Environment: The laboratory environment for this test is a team member's apartment. Lights are to be turned off and blinds are to be lowered for minimal light interference. A non-reflective backing will be used behind samples measured in an effort to minimize spectral interference.

Procedure: The following procedure outlines how the conveyor will be tested for the objectives previously outlined.

1. Assemble the conveyor setup. Make sure that the correct amount of power is supplied to the motors of the belt.
2. Turn the belt on, leaving the speed at a minimum. Does the belt move? Are there any unusual sounds being produced? Are you able to vary the speed of the belt? If any of the answers to these questions are no, troubleshoot until the issue is fixed before moving to step 3.
3. Set up the spectrometer and software as explained in section 7.1.1.
4. Set up light as described in section 7.1.3.
5. Turn on the belt. Place a sample on the belt at the default speed, and manually take spectrums at 5 locations on the bottle. Is the spectrum clear? Were 5 samples taken, or is one or more of the spectrums images of the background? If any of the answers to these questions are no, vary the speed of the belt until the spectrums taken are satisfactory.

Conclusion: The speed of the conveyor belt should be calibrated after this test. If any critical issues with the conveyor are detected, the belt must be rebuilt and the test postponed. All reference spectrums should be taken with the sample on top of the conveyor material so that spectrum readings are accurate.

7.1.7 Trash Chute Testing

Objective: The style and angle of the trash chute matter to the orientation at which the trash travels on the conveyor belt. The objective of this test is to confirm that the chute under consideration will deliver properly oriented trash.

Environment: The laboratory environment for this test is a team member's apartment. No special environmental precautions must be taken.

Procedure: The following procedure outlines how the flapper will be tested for the objectives previously outlined.

1. Assemble the conveyor setup as described in 7.1.6.
2. Assemble the chute mechanism. Adjust the chute so that it is at a 45 degree angle to the conveyor belt. Make sure that the delivery mechanism doesn't touch the conveyor assembly.
3. Drop trash of different sizes and shapes into the chute. Are the objects in the intended orientation upon delivery to the conveyor belt? Do the objects remain on the belt? If the answer is no to either of these questions, move to step 4. If the answer is yes to both, complete the test.
4. Adjust the angle of the chute to the belt and record. Repeat step 3 until the answer to both questions is yes.

Conclusion: This test establishes the actual angle for proper system delivery. If this delivery method does not function as expected, new systems must be devised. The main possibility for replacement is simply placing the objects on the conveyor by hand. This presents its own issues - as established many times in this paper, many people are not careful in the manner in which they deal with their waste. Bumpers might be applied in this situation so as to change the orientation of the waste, but the functionality of this method would largely rely on people paying attention to directions.

7.1.8 Flapper Testing

Objective: The flapper being utilized in this project must successfully be able to guide waste into appropriate bins. This test will determine if the current flapper design will fulfill this requirement. This test will require the use of two plastic bins, the flapper, and the conveyor belt. The servo motor for the configuration will not be included in this test. The purpose for this is to test the functionality of the flapper before finalizing the method of sorting and the code for the motor's function.

Environment: The laboratory environment for this test is a team member's apartment. No special environmental precautions must be taken.

Procedure: The following procedure outlines how the flapper will be tested for the objectives previously outlined.

1. Assemble the waste chute and the conveyor belt as outlined in 7.1.6 and 7.1.7. Place the conveyor belt so that the last inch hangs over the very edge of the counter.
2. Place the flapper configuration on the top of the counter so that the flapper construction straddles the conveyor belt, and the flapper itself is positioned in an appropriate position at the end of the belt. Allow the stick at the end of the flapper configuration to dangle in a manner that allows it to be controlled by a team member.
3. Place bins side by side under flapper. Make sure bins aren't too far from the side of the counter.
4. Have one team member turn on the belt while the other controls the flapper. Place an item on the belt, and see how the item responds to the flapper's attempt to guide it into the correct bin.

Conclusion: This test will confirm the flapper's functionality if no issues arise with the flapper. Several possible problems are anticipated for troubleshooting. The first of these is orientation; if trash is incident in an incorrect orientation then a jam might occur, causing this and potentially other items to not be sorted at all. The next of these is the issue of non-recyclable plastic items that are made of recyclable material being sorted into the recyclables incorrectly. Since these items are nearly always light - such as bubble wrap and lunch-style baggies - they can be easily sorted through light suction. The need for this solution will be assessed upon testing.

7.1.9 Power System Testing

The power system of the CAWSS will undergo comprehensive testing in the breadboard before proceeding to manufacture the final PCB design. The power systems are tested by attaching the 12V battery to the breadboard and simulating the behavior of the linear voltage regulators using different load resistors that simulate different load conditions. Additionally, the current draw will be monitored in each trace when simulating the full load condition.

To achieve this, the PCB circuit will be reproduced entirely in the breadboard and the spectrometer driver will be represented by a resistor. This load resistor will be changed from high resistance to lower resistance and the current in the input and output traces of the LDO will be recorded. This is carried out to test the performance of the LDO and to check that currents do not exceed the limits permitted by the designated trace width. This same exercise will be conducted for the LDO driving the microcontroller.

Moving on, the trace powering the relay solenoids is attached to the same voltage source as the traces powering the voltage regulators. To verify the actuation of these solenoids does not interfere with the stability of the LDOs, an oscilloscope must be attached to the input terminal of the regulators. The relays will then be actuated in a summing fashion and the voltage waveform will be monitored. This test is carried out to verify the switching of inductive loads (relay coils) is not producing voltage fluctuations within the trace.

Finally, the motors and bulbs will be connected to their corresponding relays in the breadboard. The same protocol used to actuate the relays will be carried out, and the current and voltage in the trace powering the relay switches will be monitored while the motor and bulbs are energized. This will help ensure the main battery trace does not exceed the maximum current permitted by trace width.

7.1.10 PCB Testing

The PCB will be tested upon receipt for continuity. This is performed with a digital multimeter by placing a probe in a trace, and then taping the remaining traces with the other probe. This is done to double check all traces are isolated from each other and allows the detection of a short circuit before components are assembled and energized. Once all components are soldered and the PCB is assembled, the exercise should be repeated to double check the soldering did not cause a short circuit.

Next, the traces that have a constant voltage will be evaluated using a digital multimeter to ensure the proper voltage is supplied at that net. The net

supplying 12V to the relays should always sit at 12V regardless of the operation of the relays. On the same note, the functioning of the relays will be verified once the components are installed in the PCB. This is done by providing 3.3V to the resistor at the base of the transistor and checking for continuity on the relay terminals.

The net supplying 3.3V and 5V to the microprocessor and spectrometer driver can also be checked for voltage, however, this should be done with an oscilloscope instead of a multimeter. Besides providing a steady voltage, these nets should also be free of noise since they will be powering processors that are potentially sensitive to noise. This exercise must be performed with the relays off and repeated with the relays energized and providing power to the lightning and motor systems.

7.1.11 Servo Motor Testing

Objective: The servo motor used in our design will drive the flapper as described in section 7.1.8. Prior to fully implementing the design, we will test that the servo responds as expected to output from the MCU software (as described in section 7.3), and carefully test to find its maximum rotational range. We will then test that it can easily move the expected load it will drive (the weight of the flapper) within this range.

Environment: This component will be tested at a group member's apartment, using an Arduino and its Servo software library. This will be similar to our actual use-case with the ATmega MCU, and provide easy control over the motor. The design of this experiment also assumes that a prototype design for the flapper and its attachment method to the servo is completed.

Procedure: The following steps outline how the servo motor will be tested for the aforementioned objectives.

1. Secure the servo on a stable surface where it is easy to evaluate its movement.
2. Connect the servo to the Arduino - its 5V power and ground wires should be connected to the appropriate pins, and the signal wire should be connected to any digital pin designated for PWM output (this is marked on the board).
3. Load the *Sweep* example code in the Arduino IDE onto the board to test these servo's range. It will start at 90°, slowly moving to its maximums at 0° and then 180°. If the servo appears to have trouble reaching these limits (ie: a grinding noise was made), reduce these ranges by 1 degree

and test again. Repeat this step until a safe maximum range has been found, and note the degree values used.

4. Securely attach prototype flapper (or replacement of approximately the same weight and size) to the servo motor, in the same manner as the final design will require.
5. Run the *Sweep* code again, using the maximum ranges found in step 3. Note whether the motor struggled to move the prototype load, and how severely it struggled if so.

Conclusion: This procedure will help us to thoroughly calibrate and test the servo motor purchased for the CAWSS. It primarily serves to find the maximum safe range the servo can be programmed to travel without risking damage to itself, as the internal gear assembly of these motors is delicate. More critical to the CAWSS's design will be the final result of the procedure. Though we do not expect the flapper to be particularly heavy, we will either redesign the flapper or purchase a more powerful servo if the tested one struggled considerably to move it.

7.2 Software Environment

Our software development requires the use of two different software environments, one for the MCU and one for the Raspberry Pi. We are proceeding with development as if we were implementing an ATmega-based MCU, and are thus able to use the extremely friendly Arduino IDE for development on this component.

Development in the Arduino IDE is done in the same C/C++ supported by Microchip Technology (previously Atmel)'s compilers for these languages. Using this IDE also provides us with access to the excellent Arduino libraries for any additional functionality required. If necessary Microchip's official IDE provides powerful additional tools, such as a simulator of the chip to step through each line of code or assembly instructions, as well as allowing direct use of assembly language. In practice, we do not expect the MCU's software to grow complex enough to need many advanced libraries or analysis, and will likely perform all software development within the Arduino IDE.

The Raspberry Pi, on the other hand, offers a much wider variety of programming languages. Thankfully, rather than needing to compare many different languages, we are limited by support for the SeaBreeze API. This API was originally created in C/C++, and is also available in Python via the excellent `python-seabreeze` modules, described in-depth in section 5.8.2. C and C++ offer increased potential for performance optimization, but require much more low-level programming work. Python takes care of much of the intricacies of

programming. This has the added benefit of making it extremely popular among data scientists and optical engineers, giving us access to a wide range of plug-and-play analysis libraries that would have required much more work in C.

For these reasons, we will be using Python as the programming language for all operations completed on the Raspberry Pi. Our development will specifically be done using Python 3, using the same Geany text editor that comes pre-installed on the Pi Foundation's Raspbian operating system. More advanced Python IDEs exist, but do not offer any real benefits over a simple text editor. Using Python and a readily-available editor like Geany also helps ensure that our development can be done on any group member's computer as long as the same Python libraries are installed.

7.3 Software Testing

As described in earlier sections, our software is split into two main parts. The first runs on our MCU, and will coordinate the low-level input and output functions of the device. The second runs on the Raspberry Pi, and is responsible for communicating with the FlameNIR spectrometer and analyzing its output. To evaluate the overall system, it will be most beneficial to test each of these systems individually first. This way, the functionality of each system can be tested on its own merits, controlling some of the variables our overall architecture introduces to an experimental setup.

MCU Software Testing

Objective: The MCU must produce the expected output necessary to control system components such as the conveyor belt or servo motor. It must properly respond to input sources, like the sensor used to detect a user's presence or the result of spectral analysis received from the Raspberry Pi. All interrupts and changes in the MCU's power state must be properly configured such that they do not block a part of the device's sequence of actions.

Environment: This component will be tested at a group member's home. Analog/PWM outputs produced for the motors will be verified using the Analog Discovery Kit's oscilloscope - more thorough testing of these components will be done separately. To simplify experimental setup, simple digital inputs and outputs will be evaluated using stand-ins - an LED will represent these outputs, and a simple push-button will be used for each digital input. The only exception to this is the input used to receive spectral analysis results from the Pi, which will be modeled with a digital switch for more reliable test procedure. An "Interrupt LED" will be turned ON only during ISR execution, to verify that the MCU properly enters/exits low-power states to perform its duties.

Procedure: The following procedure outlines how our MCU software will be tested for the objectives previously outlined. It assumes that software has been written to an acceptable level to begin test procedures, and that any failure to meet expectations will be remedied before restarting these procedures.

1. Connect stand-in input/output devices:
 - a. Connect button to each of the MCU's pin 2, 3, and 4 - connect a switch to pin 6.
 - b. Connect LEDs to pins 6, 7, 8.
 - c. Connect servo data pin (pin 9) to oscilloscope channel 1. Connect motor data pin (pin 10) to oscilloscope channel 2.
2. Load the software being tested onto the MCU and power it up.
3. Press the button connected to pin 2 (Sensor #1). The MCU should exit Power-down mode, turning pin 6 and 7's LEDs (Interrupt indicator and Lamp Enable) on, producing correct motor output on each oscilloscope channel. Pin 6's LED will turn off when the MCU returns to Idle mode.
4. Press the button connected to pin 3 (Sensor #2). Pin 6's LED will blink as the MCU briefly exits Idle mode to stop all motor output and turn on pin 9's LED (Trigger for Pi).
5. Set the switch connected to pin 5 to the ON position (representing a "plastic" result from the Pi), and press the button connected to pin 4. Again, pin 6's LED should blink as the MCU exits Idle mode to restart motor outputs and turn OFF the LED on pin 8.
6. After a timer interval set in the program, pin 6's LED will blink as the MCU exits Idle mode to disable motor output and finally return to Power-down mode.
7. Repeat steps 1-6, this time setting the switch on pin 6 to the OFF position.

Conclusion: Completing this test procedure will allow us to evaluate whether the MCU software properly addresses each task it must complete, in the sequence it must complete them. Embedded software development is an intricate process, and device functionality can easily become stuck due to careless access to memory or misconfiguration of ISRs and timers. Once the MCU software satisfies this testing independently, the placeholder input/outputs can be replaced (one by one) with their real counterparts to test their ability to work in conjunction with the MCU software as well.

Raspberry Pi Software Testing

The design of our software architecture on the Raspberry Pi is significantly more complex, as it is solely responsible for the completion of spectral analysis.

Realistically, the testing of this software component cannot be simplified to a simple procedure. For this reason, this section will focus specifically on testing whether the Pi's software can properly respond to its input and output requirements. Attempting to test our spectral analysis algorithms as a part of this process would add far too many uncontrolled variables to our testing procedure; more thorough testing of these algorithms is found in section 7.1.3.

Objective: On receiving a start trigger from the MCU (modeled by a single push-button input), the Pi will execute our analysis function. This function will verify that the Pi can successfully gather a spectrum from the FlameNIR, before returning an analysis result - either through the use of a complete spectral analysis algorithm, or as dictated by a debugging variable in order to test all other functionality on the Pi without the additional complexity the algorithm introduces. When the function finishes executing, the Pi must send a digital HIGH pulse to the MCU to wake it. A second digital output will be set to HIGH or LOW based on the analysis function (HIGH when it returns 1, LOW when it returns 0 - corresponding to whether a match was found or not). Each of these outputs will be modeled with an LED to simplify experimental procedures.

Environment: The Pi's software will be evaluated many times during the design process, but can be fully evaluated at a group member's home. Testing the software with the procedure in this section only requires the Pi, 2 LEDs, and a push-button. The tests in this section can be included as part of a broader test with the procedures outlined in section 7.1.3 - in that case, all of the environment specifications described there must also apply.

Procedure: The following procedure outlines how the software running on the Pi will be evaluated to determine whether it can meet its objectives in the test environment.

1. Connect all stand-in input/output devices:
 - a. Connect a push-button to GPIO 2.
 - b. Connect LEDs to GPIO 3 and 4.
2. Plug the FlameNIR into one of the Pi's USB ports.
3. Start the Pi's software from a terminal (remotely or on a HDMI monitor). If the software will be started in debug mode, set the `debug_output` variable to either 1 or 0 to determine the dummy result. Otherwise, refer to section 7.1.3 for more thorough testing of our spectral analysis algorithm.
4. Verify that the software successfully accessed the FlameNIR. If the device could not be accessed, troubleshoot the software or physical connection to the Flame based on the error the *SeaBreeze* module printed to the

terminal (there is little reason for this to occur, but it should be checked after any major changes in software or physical environment).

5. Press the button connected to GPIO 2 (MCU Trigger Pulse).
6. The Pi should turn on the LED connected to GPIO 3. The LED connected to GPIO 4 will be ON or OFF based on the result given by the analysis function.

Conclusion: This procedure will be primarily used to test whether the Pi can communicate electrically with other components in the device; for example, whether it responds to a trigger from the MCU, and whether it can properly respond to that trigger. It also includes some basic checks of its connection to the FlameNIR spectrometer, and can optionally include the tests outlined in section 7.1.3 once a basic test pass in debug mode without the need for spectral analysis has been completed.

8 - Administrative Content

Project milestones have been considered with both senior design milestone dates and self-set team milestone dates. These considerations were made with both grades and project completion under consideration. Some due dates for Senior Design 2 are estimates.

8.1 - Milestones

The milestones required for Senior Design 1 are listed in table 18. These milestones must be met for successful completion of Senior Design 1. Additionally, listed assignments serve as a guide for project development.

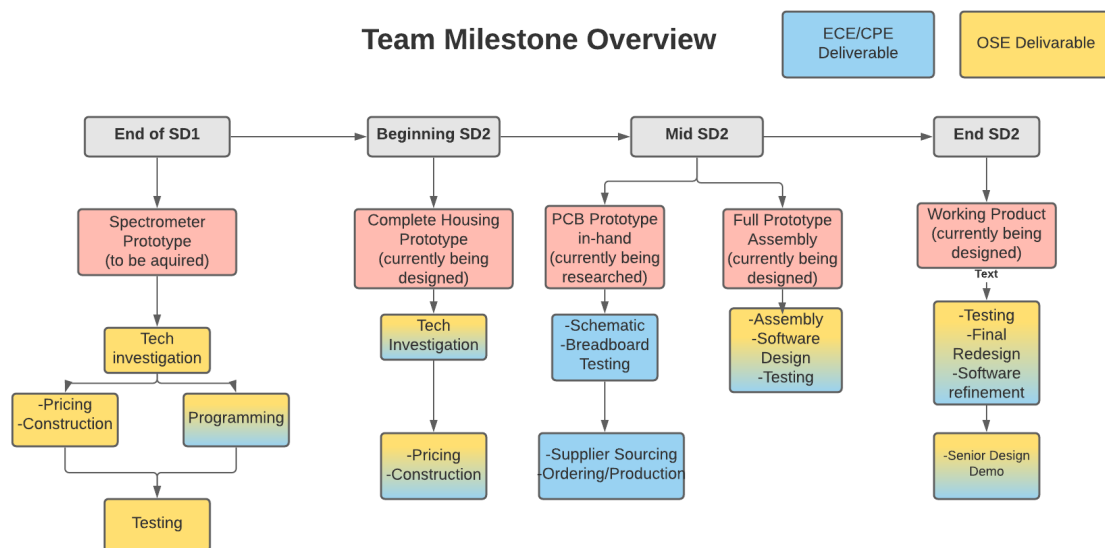

Figure 42. Team Milestones with Executable Steps

8.1.1 - Class Milestones SD2

The significant Senior Design 2 milestones are listed in table 19. The lack of a 2021 Senior Design 2 syllabus resulted in some due dates being estimated. The final form of CAWSS will be demonstrated at the Senior Design 2 demo day.

Milestone	Due Date
Bootcamp Assessment	6/04/2021
Divide and Conquer	6/11/2021
Divide and Conquer 2	6/25/2021
Standards Assignment	7/02/2021
60 Page Documentation Draft	7/09/2021
100 Page Submission	7/23/2021
Optics Demo	7/27/2021
Final Paper	8/03/2021

Table 18. Senior Design 1 Milestones

8.1.2 - Team Milestones

The development modules set by the team are summarized in the block diagram in figure 22. Each module (indicated in pink) marks an important step in completing the project in a timely and efficient manner. The subgroup responsible for each submodule is indicated with their associated color. The spectrometer was chosen as the first milestone since it is the central component of the CAWSS. It will be presented as the optical prototype during the optics demo on July 27th. The CAWSS housing and PCB will be developed and assembled during the period between SD1 and SD2. This will allow the team to produce a working product before the Senior Design demo in late fall.

Milestone	Due Date
Critical Design Review	Early SD2 - exact date TBA
Midterm Demo	Mid SD2 - exact date TBA
Final Demo	End SD2 - exact date TBA

Table 19. Senior Design 2 Milestones

8.2 - Initial Budget and Financing Discussion

The estimated optical budget (table 20) and electrical budgets (table 21) is presented below. All financing is currently being provided out-of-pocket by team members up to a maximum of \$2000. Duke Energy, Siemens, and OUC will be contacted in an attempt to borrow solar panels. Newport, Thorlabs, and Edmund Optics will be contacted in search of donations or loans. Any successful acquisition attempts could result in significant cost reduction. This table will be updated as needed so as to reflect any changes in design and component sponsorship.

The current estimated cost of our project is roughly \$1,028.48. It is hoped that this amount can be reduced by reaching out to appropriate donors for many of the optical components. The NIR range is a less commonly used portion of the optical spectrum, and offers little in the way of affordable components. This was taken into account when selecting the project, and the budget was developed accordingly. NIR photodiodes are generally made of InGaAs, and prove to be wildly expensive in large arrays. The single pixel photodiode was chosen to minimize this cost, and brought what would otherwise have cost thousands of dollars into the double-digit range.

Component Type	Component	Manufacturer	Price	Quantity
Optics	100 W Solar Cell	Grape Solar	\$81.29	2
Optics	Light Sources	Various	\$50	1
Optics	Silver Mirror	Thorlabs	\$155	1
Optics	Flame NIR Spectrometer	Ocean Insight	On loan - originally \$3,412.00	1
Optics	Fiber	Thorlabs	\$154	1

Table 20. Estimated budget for optical parts.

Component Type	Component	Manufacturer	Price	Quantity
Electrical	Stage actuator with stepper motor	Toauto	\$67.00	1
Electrical	Linear Regulator LT3042	Analog Devices	\$8.79	1
Electrical	STM32 Nucleo-32 development board with STM32L432KC MCU	Diginex	\$23.99	2
Electrical	AD8656 op-amps	Analog Devices	\$3.85	2
Electrical	Analog to Digital Converter	Analog Devices	\$12.11	1
Electrical	SFH 4545 IR LED	ORAM Opto Semiconductor	\$0.81	2
Electrical	TSSP4038 IR Receiver	Vishay Semiconductor	\$1.12	2

Table 21. Estimated budget for electrical interface parts

8.3 Parts Acquisition and Bill of Materials (BOM)

The following section will provide an in-depth view into our team's rationale for choosing specific vendors for certain components while also showing how availability of components slightly altered some of the selections for components. Sacrifices had to be made due to component availability which challenged us to be able to design around some of the changes made when selecting components. Our budget also changed as a result of component selection and availability. Also discussed will be future components yet to be purchased as well as any updates for the purchasing of future components.

8.3.1 Acquisition of OceanInsight Flame NIR Spectrometer

Initially in our design, we anticipated designing and building a spectrometer that had a photodiode on a stepper motor to fill the responsibility of obtaining an emission spectrum for analyzing different objects. While this was achievable, we received the opportunity to be able to use an OceanInsight Flame NIR spectrometer at no-cost. Due to our budget being somewhat limited, this was an

Component Type	Component	Manufacturer	Price	Quantity
Electrical	L293D Motor Controller	STMicroelectronics	\$4.26	1
Electrical	DC Motor	Hilitand	\$37.93	1
Electrical	High Torque Servo	Adafruit	\$11.95	1
Electrical	ULN2003 Stepper Driver IC	Diodes Incorporated	\$0.46	1
Electrical	7.2V 5000mAh NiMH High Capacity Battery Pack, 2 pack	Geilienergy	\$32.99	1
Electrical	PCB (2 revisions)	Vendor TBD	~\$140	1
Misc	Conveyer Belt	Treadmill Doctor	\$64.99	1
Housing	25mm T-Slot Quad Track	Orange Aluminum	\$23.50	1

Table 22. Estimated budget for housing and conveyor parts

opportunity that we jumped at which has since shown significant cost and time savings so far. The Flame NIR spectrometer is capable of performing NIR spectroscopy at a wavelength of 970-1700 nm. This is the ideal spectral range for the types of materials we are trying to identify, per the literature.



Figure 42. OceanInsight Flame NIR Spectrometer

The Flame NIR spectrometer is compact and rugged with its 89.1 mm x 63.3 mm x 31.9 mm size in its entirety. It is also somewhat easy to use as it allows it to be operated with a Raspberry Pi. Another additional benefit to the Flame NIR spectrometer is low power usage drawing less than 250 mA at 5 volts. This low

power draw is ideal for the application our team will be using it for and it also contributes to the environmental sustainability of our design.

8.3.2 Acquisition of SMA-to-SMA Fiber Optic Patch Cable

A fiber optic cable is an effective way of directing a large percentage of light from our light source into the spectrometer. Our team matched the numerical aperture of the spectrometer with the numerical aperture of the fiber optic patch cable in order to ensure the largest amount of light possible to be directed into the Flame NIR spectrometer.

We acquired a 0.22 NA, Low OH (400-2200 nm), Step-Index, Multimode Fiber Optic Patch Cable from Thorlabs for 145.50 USD on June 17th, 2021 which was received on June 20th, 2021. Our team decided to source the fiber optic cable from Thorlabs because of Thorlabs notable reputation of one the best optical component manufacturers that is domestic. There were cheaper international-based sellers of cables with similar specifications but shipping and lead time was a large priority for us which is why we chose to go with a U.S. based company. We also paid extra to receive 5 meters of the cable rather than the standard 1 meter size because the larger size enabled greater flexibility for the location of our spectrometer relative to the end of the fiber optic cable.



Figure 43. Thorlabs Step-Index Multimode Fiber Optic SMA-to-SMA Patch Cable

8.3.3 Acquisition of Lens

Although our team was able to capture a spectrum from objects without a lens, the lens was able to increase the intensity of the signal without having to increase the power of the bulb being used. This was of great importance because as our light source became more powerful and since it is an incandescent, it produced more heat which over long periods of time could affect the performance of the spectrometer and the fiber. Therefore, by increasing the intensity of light reaching the fiber without increasing the wattage of the bulb, our team was able to obtain a more defined signal without increasing the amount of heat that enters the system.



Figure 44.Thorlabs N-BK7 Plano-Convex Lens

As shown above, our design used a Thorlabs N-BK7 Plano-Convex Lens with a 150 mm focal length and an AR coating for 1050-1700 nm. Due to the position of the lens in relation to the location of the objects, a large focal length was desired in order to effectively collect light from a moderate distance away from the object since the lens position cannot be on the conveyor belt. Also, the lens purchased has a 3-inch diameter which is ample to collect a large enough amount of light to effectively couple a greater quantity of light into the end of the fiber. An AR coating rated for 1050-1700 nm was desired to allow light in that wavelength to pass through the lens with minimal distortion. The lens was purchased from Thorlabs for 132.97 USD on 7/9/2021 and received on 7/13/2021.

8.3.4 Acquisition of Light Source and Housing

Light sources proved to be a difficult thing to predict the efficacy of in our design due to the sources being purchased being geared towards the consumer industry and not towards the scientific community. As a result, the undesired trial and error finally ended up becoming the primary component selection decision-making process for this part of the design. Our team tested the different sources shown below to determine which light source would prove most effective at giving us the best signal possible with our spectrometer.



Figure 45. (From left to right) 100 and 250-Watt 2700K FEIT Electric Incandescent bulb, 60-Watt Sylvania Incandescent Bulb, and 7-Watt 3000K FEIT Electric Incandescent bulb (Wedge)

We purchased a a 7-Watt 3000K FEIT Electric Incandescent bulb (Wedge), a 60-Watt Sylvania Incandescent Ceiling-Fan Bulb (A15), a 100-Watt 2700K FEIT Electric Incandescent bulb (T3 R7), and a 250-Watt 3000K Incandescent bulb (T3 R7). Additionally, a T5 socket, A15 socket, and HDX Portable Halogen Work Light housing were all purchased for roughly 60 USD in June, 2021. Our team decided on using the 100-Watt Incandescent bulb with the HDX Portable Halogen Work Light to achieve the best results. All of the bulbs as well as the HDX Work Light were purchased at Home Depot and the sockets for the bulbs were purchased online through Amazon.

8.3.5 Acquisition of Lens Holder

Lens mounts through companies such as Thorlabs and Edmund Optics typically start at around 75 dollars and can be upwards of thousands of dollars. Adjustable lens mounts are typically more expensive and harder to find. Also, our team was not able to find an adjustable lens mount that was able to accommodate our lens which is 3 inches in diameter. An adjustable lens mount was desirable in case our lens needed to be returned and exchanged for a different size lens. Our team designed a V-shaped adjustable lens mount that is capable of holding lenses from half an inch to 4 inches. This lens mount was printed at University of Central Florida for no cost and was designed via free software available online. This created major cost savings for our team and also gave us the breathing room needed in the event of the lens ordered not doing what is need and for a different lens being placed in the mount

8.4 Project Roles

In many senior design groups, specific work is assigned to group members based on their degree program because it is believed that is where the individual will work best. Within our own team as well, work was dedicated to group members based on their individual strengths and weaknesses which we believe had a large impact on the overall success of our project. This commonly involved people jumping outside of their academic experience and being able to assist other group members on parts of the project that may seem unconventional to someone else with their experience. By doing this, our team was able to work as efficiently as possible, cultivating a positive work culture and supporting other group members when faced with setbacks in the design process.

Melissa Siver and Troy Rzeznikiewicz worked primarily on the optical design for the CAWSS and related parts selections, providing valuable input on the mathematics required for our software to perform all spectral analysis tasks. Melissa Siver also researched existing and relevant technologies, selected components, and contributed immensely to the design of our optical subsystem

and its test procedures, communicating directly with Ocean Insight to source our spectrometer. Troy Rzeznikiewicz contributed towards the overall conception and description of our project design, helped devise realistic constraints and testing for optical subsystems, and contributed to these subsystems' design, as well as providing the initial design for a 3D-printed lens mount. Clyde Bujari worked primarily on the project's software design, developing a custom solution to analyze spectral data from the FlameNIR and direct output interfaces based on this analysis. Clyde was also responsible for selecting components, designing subsystems, and writing test procedures related to this software architecture, as well as creating a usable CAD model for the lens mount and researching standards applicable to the CAWSS. Juan Soto led much of our electrical subsystem design and related component selections, and created schematics and PCB designs for the CAWSS. Juan was also responsible for designing test procedures related to the PCB and other electrical hardware subsystems, as well as providing input on overall system design and many other subsystems' component selections.

Having a wide variety of different skill sets and backgrounds of knowledge ultimately led to fruition of a design that started as just an idea. Being able to work on parts of the project we felt knowledgeable about, and receiving support from others on the team when stuck helped make this process a more enjoyable and productive task which ultimately led to our growth as future engineers and lifelong learners. Our team is grateful for the opportunity of being able to participate in engineering design and will be looking forward to continually improving upon our design in the future.

8.5 Project Design Challenges

With any project, there are unanticipated challenges that arise during design, testing, integration, and operation. Our team faced numerous challenges that were not previously predicted to be issues for our project. On the bright side, we were able to implement effective solutions that cleared the majority of the issues up.

One of the first issues we ran into was that plastic bags, which are commonly made from high-density polyethylene or low-density polyethylene, are manufactured from a recyclable material although the bags are not recyclable. This is because these thin plastic bags can often cause damage to the machinery within the sorting and recycling facility by getting stuck and causing jams. This meant that when we were gathering the data for our spectral database and performing the analysis, the spectrum of the plastic bags matched the spectrum for other recyclable materials even though the bag was not recyclable. This issue has started the conversation of how to work around this even though the conversation has not yet finished. One potential solution is

having a low PSI vacuum vent placed on the ceiling of the gravity chute that would be capable of only sucking up plastic bags. Another potential solution could be a low power fan that is light enough only to move plastic bags and nothing else, from one side of the chute to the other. Another approach could be a Van de Graaf apparatus that would use static electricity to attract the plastic bags. There are several ways to recycle plastic bags and many different companies that do so regardless of curbside recycling guidelines. It may be advantageous to have a sticker on the machine that instructs the consumer to ball the plastic bag up instead of throwing it away as is.

When setting up the design and getting ready to obtain spectrums to build our database, positioning of the lens relative to the fiber can be quite difficult. The slightest difference in the position of the lens relative to the fiber can alter the spectrum's intensity by quite a bit, negatively impacting the consistency of our results. One way to combat this will be to develop fixed positions for the lens and light sources once the construction of our conveyor belt is complete. This will involve following the already developed testing procedure for determining the optimal position of the lens, fiber, and light source. This will enable there to be no additional alignment once the position of the light source, fiber, and lens are determined. This will save time and allow us to continue to obtain accurate spectrums for a wide variety of different objects.

Another issue that our group ran into was how highly reflective materials were handled when taking their spectrums and comparing them against a database of other known spectrums. As a result of us measuring reflectivity of materials, highly reflective materials can be troublesome to differentiate from other highly reflective materials. For example, ceramic is a material which is not recyclable in almost any recycling programs for the general public. However, ceramic is highly reflective and identifies closely with plastic number one by giving a Pearson coefficient of about 0.98. Pearson coefficients above 0.98 are generally our criteria for deciding which objects should be considered as a potential match. Due to highly reflective materials all reflecting the same light source, this can often make these spectrums, qualitatively and quantitatively appear extremely similar. Our workaround for this, as of now, is to develop a second database of objects that are quite often troublesome for our analysis. This fixes the problem because instead of ceramic having a Pearson coefficient with plastic of 0.98, it now has a Pearson coefficient of 0.995-0.999 with ceramic depending on the variations of the material. Our design team anticipates doing this with other troublesome materials and also using this method with food waste and water. By constructing a database of food waste and liquids, we can quickly discern if an object is too contaminated to be recycled even if the material itself is recyclable. This can be a great advantage for further improving our rate of accuracy and increasing the marketability of our system.

Lastly, the mathematics behind the analysis and data collection has had its fair share of complications as well. It was known that we were going to have to develop the software to be able to differentiate spectrums but the big question to us at the time was how. There are many solutions out there such as pearson coefficient analysis (PCA), machine learning, euclidean geometry and more. The biggest problem with all of these was that the studies done for them were performed in academic environments and very rarely in any in-line testing for a commercial or industrial purpose. Also, any software that offered the option of matching spectrums to known spectrums in a database conveniently hid any of the inner workings behind their calculations and analysis. This became a guessing game for determining what the most efficient mathematical model of comparing spectrums would be for our application. Through testing, it was determined that pearson coefficient was the way to go in terms of ease of use as well as accuracy of results. It handled variation between spectrums well and was unaffected by changes in the baseline. If needed, taking the first derivative of the spectrum can further sharpen peaks and make the pearson coefficient more distinct from each other if greater accuracy is needed but as of right now, the software is performing excellent without taking the first derivative.

Looking back at the project design challenges our team has faced, it has continued to push us beyond limitations and continue to innovate at every corner. This has greatly strengthened the design, accuracy, and efficacy of our system and continued to prove that spectroscopy is and will be a valuable tool for pre-screening plastics before going to the sorting facility. Once CAWSS's accuracy and processing rate meets or exceeds the average of recycling facilities, the need for sorting facilities may be lessened, further strengthening the benefit of recycling programs across the world.

8.6 Looking Forward

While our group was determined to get as much done as possible to make this design achieve our primary engineering goals, time eventually came knocking on our door. Due to the time constraints that our group was under in this senior design project, we believe that having more time to develop additional features could potentially make our system more efficient, accurate, and marketable. One of the most obvious shortcomings of our design is the large amount of power it needs to be operational when the device is not in standby mode. Something that could reduce the overall power budget would be integrating more energy efficient and low-power components into our design. Although these components could be more expensive than non-energy efficient components, the long-term operation costs for the owner of the system would be lessened by more efficient components. Additionally, utilizing more sustainable forms of energy could contribute to a lower cost of operation design while also helping us stay true to our commitment of creating a more sustainable future. It is well

understood that solar panels are much less efficient in an indoor setting when compared to their performance in an outdoor setting. This means that our team will have to get creative about sustainable energy sources to help power our device in the future.

Another major part of the design that could be improved in the future is the software that our spectrometer operates on. Additional features such as cloud-based software downloads would enable the device to upload geographically relevant recycling guidelines based on its location that it is being used. Also, application specific software packages could be available for add-on purchases such as a post-consumer recycling package that covers most commonly seen post-consumer materials or an industrial recycling package that covers commonly used materials in industrial settings such as manufacturing or logistics. Software packages could also be purchased that would flag potentially valuable items thrown out such as certain metals or materials with recoverable precious metals such as phones or laptops. These software packages would enable the owner of the system to potentially recover his initial investment or even have a continuous cash flow resulting from valuables being recovered that previously would have been thrown away. These software packages could be offered through a subscription service or purchased outright. On the topic of software, better data analytics could be built into the software that would enable real time feedback of performance characteristics such as capacity of bins filled, error messages, waste processing rates, and future updates. By being able to provide the owners and the manufacturers of this system, future advancements may be made based on the data that the software collects about the system itself as well as consumer recycling habits.

Additionally, the processing rates and capacity of this device can be improved upon in future design by adding features such as more intuitive software to drive the conveyor belt. Currently, the conveyor belt is at a dead stop when the device is in standby mode. In the future, data collection may enable our team to develop a more intuitive standby mode that can have better reaction times when trash enters the system in order to speed up the waste processing times. Also, the largest downtime for our system is when the waste bins in it have to be emptied by a staff member. This is currently limited by the capacity of the waste bins that the device contains. Due to floor space in commercial settings being of the utmost importance, expanding the size of our waste bins will not be financially feasible from a manufacturing standpoint and will also negatively impact the commercial space that it is in. Our team believes that having a small-scale trash compactor would be a happy medium for the purchaser of the system and the design team. Having a trash compactor within the bins would enable the design's trash capacity to increase significantly without actually increasing the size of the bin.

Lastly, the biggest challenge looking forward is to be capable of producing a low-cost spectrometer in the future. This would be achieved in two major parts. The first part would be to research and determine if there are visible features in the emission spectrum of materials that could be used to identify materials. Identifying commonly disposed of materials accurately in the visible spectrum would be an incredible feat because the cost of producing a visible spectrometer is much cheaper and easier than producing a spectrometer for the near-infrared region of light. There are many different low-cost visible light spectrometer options on Amazon and other companies. Also, identifying materials by their visible light spectrums allows our team to more easily design a cost effective solution as a spectrometer. This would be ideal going forward because it would allow us to reduce the cost of manufacturing significantly. By reducing the cost to produce the spectrometer in our system, it would allow us to keep the cost of production lower and in turn, pass those cost savings down to the buyer of the system.

Our system is only meaningful, impactful, and valuable if it is marketable to the general public. This would involve substantial surveying and market research to determine what the need in society is for a product such as ours. Once this is established, it needs to be marketed in a way that creates a demand from the consumer level that has the potential of spreading to the business and real estate owners of the world. The largest challenge faced going forward from a marketing perspective would be creating awareness to the widely unknown issue we are targeting. Awareness campaigns targeting things such as wishful recycling and the environmental impact of non-recyclables being dealt with in sorting facilities may have a significant impact on the populations of people that are not currently aware of these issues. Our system is a solution to these problems on many levels and would have a positive impact on all people affected.

Bibliography

- [1]“ISO 15270:2008,” *ISO*, Jun. 2008. <https://www.iso.org/standard/45089.html> (accessed Jun. 25, 2021).
- [2]“IEC 60364-7-712:2017 | IEC Webstore | rural electrification, LVDC,” *webstore.iec.ch*, Apr. 10, 2017. <https://webstore.iec.ch/publication/28213> (accessed Jun. 25, 2021).
- [3]“IEC 60335-2-29:2016+AMD1:2019 CSV | IEC Webstore,” *webstore.iec.ch*, Mar. 29, 2019. <https://webstore.iec.ch/publication/64908>.
- [4]“IEC 62477-1:2012 | IEC Webstore,” *webstore.iec.ch*, Jul. 24, 2012. <https://webstore.iec.ch/publication/7080>.
- [5]“IEC 60906-2:2011 | IEC Webstore,” *webstore.iec.ch*, May 12, 2011. <https://webstore.iec.ch/publication/3883> (accessed Jun. 25, 2021).
- [6]“QFD Online - Free House of Quality (QFD) Templates for Excel,” *qfdonline.com*. <http://qfdonline.com/templates/> (accessed Jun. 25, 2021).
- [7]E. Guelcan, “Schematic of Optical Sorter,” *Researchgate.net*, 2021. <https://www.researchgate.net/profile/Ergin-Guelcan/publication/320253827/figure/fig1/AS:622477348700163@1525421573582/Schematic-view-of-the-optical-sorter.png> (accessed Jul. 22, 2021).
- [8]“Are you guilty of ‘Wishful Recycling’?,” *Sierra Club*, May 31, 2019. <https://www.sierraclub.org/san-francisco-bay/blog/2019/05/are-you-guilty-wishful-recycling> (accessed Jul. 22, 2021).
- [9]“Belt Speed,” *vCalc*. <https://www.vcalc.com/wiki/vcalc/belt+speed> (accessed Jul. 22, 2021).
- [10]O. Cory, “‘Stop Wishful Recycling,’ Says City of Arcata,” *Redheaded Blackbelt*. <https://kymkemp.com/2020/09/30/stop-wishful-recycling-says-city-of-arcata/> (accessed Jul. 22, 2021).
- [11]C. Araujo-Andrade *et al.*, “Review on the photonic techniques suitable for automatic monitoring of the composition of multi-materials wastes in view of their posterior recycling,” *Waste Management & Research: The Journal for a Sustainable Circular Economy*, vol. 39, no. 5, pp. 631–651, Mar. 2021, doi: 10.1177/0734242x21997908.

[12]C. Criswell, “Earth Day Challenge: Stop Wishful Recycling,” *The Watershed Project*, Apr. 10, 2019. <https://thewatershedproject.org/earth-day-challenge-stop-wishful-recycling/> (accessed Jul. 22, 2021).

[13]“Flame NIR+ Spectrometer | Ocean Insight,” *www.oceaninsight.com*. <https://www.oceaninsight.com/products/spectrometers/general-purpose-spectrometer/flame-series/FLAME-NIR/> (accessed Jul. 22, 2021).

[14]“How Does a Spectrometer Work?,” *YouTube*. May 24, 2017, [Online]. Available: <https://www.youtube.com/watch?v=OI3pIvLhVcc>.

[15]Valley Waste Service, Inc., “What Happens if You Put Non-Recyclable Items into Recycling?,” *www.valleywasteservice.com*. <https://www.valleywasteservice.com/valley-waste-news/what-happens-if-you-put-non-recyclable-items-into-recycling-4034>.

[16]LLA Instruments GmbH, “Identification and Analysis of Plastics in Recycling by NIR Hyperspectral camera KUSTA1.9MSI,” *YouTube*, Jun. 12, 2015. <https://www.youtube.com/watch?v=eIZIWSj7jlg> (accessed Jul. 22, 2021).

[17]S. Zhu, H. Chen, M. Wang, X. Guo, Y. Lei, and G. Jin, “Plastic solid waste identification system based on near infrared spectroscopy in combination with support vector machine,” *Advanced Industrial and Engineering Polymer Research*, vol. 2, no. 2, pp. 77–81, Apr. 2019, doi: 10.1016/j.aiepr.2019.04.001.

[18]A. Z. Samuel *et al.*, “On Selecting a Suitable Spectral Matching Method for Automated Analytical Applications of Raman Spectroscopy,” *ACS Omega*, vol. 6, no. 3, pp. 2060–2065, Jan. 2021, doi: 10.1021/acsomega.0c05041.

[19]“Used Optical Sorters for sale. Bell & Howell equipment & more | Machinio,” *www.machinio.com*. <https://www.machinio.com/cat/optical-sorters#results> (accessed Jul. 22, 2021).

[20]“Occupational Noise Exposure - Overview | Occupational Safety and Health Administration,” *www.osha.gov*. <https://www.osha.gov/noise>.

[21]O. of R. Affairs, “Radiation-Emitting Electronic Products,” *FDA*, Oct. 2019, [Online]. Available: <https://www.fda.gov/industry/regulated-products/radiation-emitting-electronic-products>.

[22]US EPA,OLEM, “Household Hazardous Waste (HHW) | US EPA,” *US EPA*, Nov. 25, 2015. <https://www.epa.gov/hw/household-hazardous-waste-hhw>.

[23]J.-Y. Tang, N.-Y. Chen, M.-K. Chen, M.-H. Wang, and L.-S. Jang, “Dual-wavelength optical fluidic glucose sensor using time series analysis of d(+)-glucose measurement,” *Japanese Journal of Applied Physics*, vol. 55, no. 10, p. 106601, Sep. 2016, doi: 10.7567/jjap.55.106601.

[24]Microchip Technology, Inc., “ATmega640/1280/1281/2560/2561 Datasheet,” Microchip Technology Inc., Feb. 2014. Accessed: Jul. 13, 2021. [Online]. Available: <https://ww1.microchip.com/downloads/en/DeviceDoc/ATmega640-1280-1281-2560-2561-Datasheet-DS40002211A.pdf>.

[25]“Choosing and Sizing Batteries, Charge Controllers and Inverters for Your Off-Grid Solar Energy System,” *solartown.com*. <https://solartown.com/learning/solar-panels/choosing-and-sizing-batteries-charge-controllers-and-inverters-for-your-off-grid-solar-energy-system/> (accessed Jul. 22, 2021).

[26]“Solar Charge Controller Basics,” *Northern Arizona Wind & Sun*. <https://www.solar-electric.com/learning-center/solar-charge-controller-basics.html/>.

[27]“Solar 101 - Beginners Guide to Solar Energy & Panels,” *Semper Solaris*. <https://www.sempersolaris.com/resources/solar-information/solar-for-beginners/> (accessed Jul. 22, 2021).

[28]Solar Energy Technologies Office, “How Does Solar Work?,” *Energy.gov*. <https://www.energy.gov/eere/solar/how-does-solar-work>.

[29]SunPower, “Solar Array Definition,” *SunPower - United States*, Jun. 24, 2019. <https://us.sunpower.com/solar-array-definition>.

[30]N. Pflueger-Peters, “BAE senior design projects showcase innovation in sustainability,” *Biological and Agricultural Engineering*, Jun. 05, 2020. <https://bae.ucdavis.edu/news/bae-senior-design-projects-showcase-innovation-sustainability> (accessed Jul. 22, 2021).

[31]“Capstone Design Q&A: Sorting waste has never been easier,” *Paul M. Rady Mechanical Engineering*, Mar. 06, 2020. <https://www.colorado.edu/mechanical/2020/03/06/capstone-design-qa-sorting-waste-has-never-been-easier> (accessed Jul. 22, 2021).

[32]Ole Miss News Admin, “Student recycling sorter selected as one of best,” *Ole Miss News*, Nov. 30, 2021. <https://news.olemiss.edu/student-recycling-sorter-selected-as-one-of-best/> (accessed Jul. 22, 2021).

- [33]D. R. Paschotta, “Multimode Fibers,” *www.rp-photonics.com*. https://www.rp-photonics.com/multimode_fibers.html (accessed Jul. 22, 2021).
- [34]“Single Mode vs Multimode Fiber: What’s the Difference?,” *Blog*, Mar. 22, 2017. <https://community.fs.com/blog/single-mode-cabling-cost-vs-multimode-cabling-cost.html>
- [35]“Top 10 Safety Rules for Fiber Optics,” *Network Cabling Los Angeles*. <https://www.networkcablinglosangeles.com/top-10-safety-rules-fiber-optics/>.
- [36]“Part 8: Fiber Optic Probes,” *B&W Tek*. <https://bwtek.com/spectrometer-part-8-fiber-optic-probes/> (accessed Jul. 22, 2021).
- [37]Viva, “12 Difference Between Step Index Fiber And Graded Index Fiber (With Pictures),” *Viva Differences*, Jan. 10, 2020. <https://vivadifferences.com/difference-between-step-index-fiber-and-graded-index-fiber/#:~:text=Description-> (accessed Jul. 22, 2021).
- [38]“An Introduction to a Spectrometer: Choosing a Fiber Optic,” *AZoM.com*, Dec. 02, 2016. <https://www.azom.com/article.aspx?ArticleID=13371> (accessed Jul. 22, 2021).
- [39]“SeaBreeze API Documentation,” *www.oceaninsight.com*. <https://www.oceaninsight.com/globalassets/catalog-blocks-and-images/software-downloads-installers/javadocs-api/seabreeze/html/index.html> (accessed Jul. 13, 2021).
- [40]“python-seabreeze: Python module for oceanoptics spectrometers,” *GitHub*. <https://github.com/ap-/python-seabreeze> (accessed Jul. 14, 2021).
- [41]SciPy Developers, “SciPy.org — SciPy.org,” *Scipy.org*. <https://www.scipy.org/> (accessed Jul. 19, 2021).
- [42]“FLAMENIR+ Scientific-grade Spectrometer Installation and Operation Manual.” Accessed: Jun. 18, 2021. [Online]. Available: <https://www.oceaninsight.com/globalassets/catalog-blocks-and-images/manual--instruction-re-branded/spectrometers/mnl-1024-flamenir-series-installation-and-operation-manual-rev-a.pdf>.
- [43]The NumPy Community, “NumPy Reference — NumPy v1.19 Manual,” *numpy.org*. <https://numpy.org/doc/stable/reference/index.html>.
- [44]Operant LLC, “Essential FTIR ®: Software for Optical Spectroscopy,” *www.essentialftir.com*, 2014. <https://www.essentialftir.com/> (accessed Jul. 16, 2021).

- [45] Ocean Optics, "Flame-NIR Miniature Spectrometer User Manual," Ocean Optics, Inc., 2016. Accessed: Jul. 30, 2021. [Online].
- [46] "Spectrometer Design Guide," *Ibsen Photonics*, 2021. <https://ibsen.com/technology/spectrometer-design-guide/> (accessed Aug. 03, 2021).
- [47] "How much light can my spectrometer capture?," Ibsen Photonics. Accessed: Aug. 03, 2021. [Online]. Available: <https://ibsen.com/wp-content/uploads/Coupling-into-your-spectrometer.pdf>.
- [48] "Flame-NIR Miniature Spectrometer User Manual," Ocean Insight, 2000. Accessed: Aug. 03, 2021. [Online]. Available: <https://www.oceaninsight.com/globalassets/catalog-blocks-and-images/manuals--instructi-on-old-logo/spectrometer/flamenir.pdf>.
- [49] "The Rayleigh Criterion," *Gsu.edu*, 2019. <http://hyperphysics.phy-astr.gsu.edu/hbase/phyopt/Raylei.html>.
- [50] "Characteristics and use of infrared detectors," Hamamatsu. [Online]. Available: <https://mmrc.caltech.edu/FTIR/Literature/General/Hamamatus%20IR%20detectors.pdf>.
- [51] "Spectroscopy: The Slit," *www.optecks.com*, 2016. <https://www.optecks.com/Portal/index.php/knowledge-center/spectroscopy-root/spect3>.
- [52] "Spectrometer Throughput and Etendue," *www.horiba.com*. https://www.horiba.com/en_en/technology/spectroscopy/spectrometers-and-monochromators/spectrometer-throughput-and-etendue/ (accessed Aug. 03, 2021).
- [53] H. Zhu and P. Blackborow, "Technical Note: Etendue and Optical Throughput Calculations," *www.energetiq.com*, 2021. <https://www.energetiq.com/etendue-and-optical-throughput-calculations> (accessed Aug. 03, 2021).
- [54] "System Throughput, f/#, and Numerical Aperture | Edmund Optics," *www.edmundoptics.com*. <https://www.edmundoptics.com/knowledge-center/application-notes/imaging/lens-iris-aperture-setting/> (accessed Aug. 03, 2021).
- [55] B. T. G. & Co.KG, "How to convert irradiance into photon flux," *Berthold Technologies GmbH & Co.KG*. <https://www.berthold.com/en-us/bioanalytic/knowledge/faq/how-to-convert-irradiance-into-photon-flux/> (accessed Aug. 03, 2021).

[56]“An Introduction to a Spectrometer: Choosing a Fiber Optic,” *AZoM.com*, Dec. 02, 2016. <https://www.azom.com/article.aspx?ArticleID=13371>.

[57]“Flame VIS-NIR Spectrometer | Ocean Insight,” *www.oceaninsight.com*. <https://www.oceaninsight.com/products/spectrometers/general-purpose-spectrometer/flame-series/flame-vis-nir/> (accessed Aug. 03, 2021).

[58]Y. Chao, “DIY Near-IR Spectrometer,” *caoyuan.scripts.mit.edu*, 2021. https://caoyuan.scripts.mit.edu/ir_spec.html (accessed Aug. 03, 2021).

[59]“Light Collection and Optical System Throughput,” *www.newport.com*. <https://www.newport.com/t/light-collection-and-systems-throughput> (accessed Aug. 03, 2021).

[60]J. Jerrett, “John Jerrett’s Homepage,” *Physics.mun.ca*, Nov. 09, 2010. <https://www.physics.mun.ca/~jjerrett/index.html> (accessed Aug. 03, 2021).

[61]“Define the Acceptance angle,” *eguruchela.com*. https://eguruchela.com/Physics/learning/Acceptance_angle.php (accessed Aug. 03, 2021).

[62]“75 Gallon Echelon Indoor Three Stream Recycling Receptacle ECH3,” *Trash Cans Unlimited*. <https://trashcansunlimited.com/75-gallon-echelon-indoor-three-stream-recycling-receptacle-ech3/> (accessed Aug. 03, 2021).

[63]trinamiX GmbH, “Mobile NIR Spectroscopy Solutions / trinamiX,” *trinamixsensing.com*, 2021. <https://trinamixsensing.com/nir-spectroscopy/mobile-nir-spectroscopy-solutions/> (accessed Aug. 03, 2021).

[64]“NIR spectroscopy software tools - LLA Instruments GmbH & Co. KG,” *www.lla-instruments.com*. <https://www.lla-instruments.com/software/nir-spectroscopy-tools.html> (accessed Aug. 03, 2021).

[65]“Team 42: BioRhythm,” *Paul M. Rady Mechanical Engineering*, Apr. 14, 2020. <https://www.colorado.edu/mechanical/team-42-biorhythm> (accessed Aug. 03, 2021).

Appendix A - Permission Request Letters

1. Permission granted for figures 9 and 10.

Re: Use of images from book

Gerd Keiser <gkeiser@photonicscomm.com>

Mon 8/2/2021 5:03 PM

To: Melissa Siver <mksiver@Knights.ucf.edu>

Cc: Gerd Keiser <gkeiser@photonicscomm.com>

Dear Melissa,

Thank you for looking at my book for your capstone project.

Yes, you may use some images from the book for your paper. With the title of each figure, just include the phrase

"Reproduced with permission from Optical Fiber Communications, McGraw-Hill, 4th edition by Gerd Keiser"

Springer published an updated version of the book several months ago, which is now called "Fiber Optic Communications."

Two people that I know well at CREOL are Bahaa Saleh and Guifang Li. It's a great place to study.

Best regards,

Gerd Keiser

2. Permission Granted for Figure 16

Re: Use of images

Safa Kasap (Professor) <sok533@usask.ca>

Tue 8/3/2021 1:29 AM

To: Melissa Siver <mksiver@Knights.ucf.edu>

Yes, you have my permission. Good luck with your report. SK

On 8/2/2021 9:39 PM, Melissa Siver wrote:

CAUTION: External to USask. Verify sender and use caution with links and attachments. Forward suspicious emails to ohishing@usask.ca

Dear Dr. Kasap

My name is Melissa Siver. I am a Photonic Engineering undergraduate student at the University of Central Florida. I am currently completing the first part of my capstone project, Senior Design I. We are required to write a paper detailing the steps taken during the planning of our project. I am writing to ask permission to use some images from a book you authored – Optoelectronics and Photonics, 2nd Ed. The images will only be used in my paper and will not be published or otherwise used for profit of any kind.

Thanks for your time,

Melissa Siver

3. Permission granted for figure 11.

Re.: Re: Use of image

Pernille.Kennedy@ibsen.com <Pernille.Kennedy@ibsen.com>
Tue 8/3/2021 2:46 AM
To: Melissa Siver <mksiver@Knights.ucf.edu>

Dear Melissa,

Thank you for contacting us with your request to use our image for your project. You are welcome to use the image you refer to in your paper as long as you refer to Ibsen Photonics.

Good luck with your project.

Best regards,

Pernille

4. Permission granted for figure 6.

AW: use of image

Lysann Simon <l.simon@lla.de>
Tue 8/3/2021 4:09 AM
To: Melissa Siver <mksiver@Knights.ucf.edu>
Dear Melissa,

thank you very much for your request. Please feel free to use our video or screenshot of the video by using **Courtesy of LLA Instruments, Berlin**. Additionally you can provide the link.

Good luck with your project.

Please do not hesitate to contact us, in case you have any questions.

best regards,

Lysann Simon
Manager Sales & Marketing

LLA Instruments GmbH & Co. KG
Justus-von-Liebig-Str. 9/11
12489 Berlin

5. Permission given for figure 14.

Re: Use of Image

John Jerrett <jjerrett@mun.ca>
Tue 8/3/2021 7:22 AM
To: Melissa Siver <mksiver@Knights.ucf.edu>

Hi Melissa,

Yes, you may use the image for free. Thank you for taking the time to ask for permission. I wish you the best with your paper.

John Jerrett

On 8/3/21 12:48 AM, Melissa Siver wrote:

Dear John,

My name is Melissa Siver. I am a Photonic Engineering undergraduate student at the University of Central Florida. I am currently completing the first part of my capstone project, Senior Design I. We are required to write a paper detailing the steps taken during the planning of our project. I am writing to ask permission to use the image below (found at <https://www.physics.mun.ca/~jjerrett/mirror/concavem.html> on your website) in my paper. The images will only be used in my paper and will not be published or otherwise used for profit of any kind.

6. Permission given for figure 13

Re: Use of image

Rod Nave <rodnave@gsu.edu>
Tue 8/3/2021 8:31 AM
To: Melissa Siver <mksiver@Knights.ucf.edu>
Cc: rodnave <rodnave@mail.phy-astr.gsu.edu>

Dear Melissa,

You are welcome to use the image from HyperPhysics as you describe.

Best wishes with the paper and your continuing education.

Regards,
Rod Nave RodNave@gsu.edu
Department of Physics and Astronomy
HyperPhysics Project
Georgia State University
Atlanta, GA 30302-5060

7. Requested permission for figure 12

Melissa Siver <mksiver@Knights.ucf.edu>
 Mon 8/2/2021 11:08 PM
 To: info@analytik.co.uk <info@analytik.co.uk>

Dear Sir/Madame

My name is Melissa Siver. I am a Photonic Engineering undergraduate student at the University of Central Florida. I am currently completing the first part of my capstone project, Senior Design I. We are required to write a paper detailing the steps taken during the planning of our project. I am writing to ask permission to use the image below (found at your website here: <https://analytik.co.uk/what-is-remote-sensing/>) in my paper. The images will only be used in my paper and will not be published or otherwise used for profit of any kind.

8. Permission granted for figure 3

Silvia Cortes <scortes@ex-cell.com>
 Tue 8/3/2021 11:02 AM
 To: Melissa Siver <mksiver@Knights.ucf.edu>
 Good morning Melissa,

Thank you for your email and interest in our product.

We approve the use of the Echelon Receptacle image as long as there is a reference that it is an Ex-Cell Kaiser product. It can be in small print under the image or reference/source acknowledgement page within your paper.

Thank you,



Customer Service
 Ex-Cell Kaiser, LLC
 11240 Melrose Avenue
 Franklin Park, IL 60131
 P: (847) 451-0363 | F: (847) 261-9448
service@ex-cell.com

9. Requested permission for figure 4

Melissa Siver <mksiver@Knights.ucf.edu>
 Tue 8/3/2021 12:03 AM
 To: csecommerce@thermofisher.com <csecommerce@thermofisher.com>
 Dear Sir/Madame

My name is Melissa Siver. I am a Photonic Engineering undergraduate student at the University of Central Florida. I am currently completing the first part of my capstone project, Senior Design I. We are required to write a paper detailing the steps taken during the planning of our project. I am writing to ask permission to use the image below (found here: <https://www.thermofisher.com/order/catalog/product/MICROPHAZIRPC#/MICROPHAZIRPC>). The images will only be used in my paper and will not be published or otherwise used for profit of any kind.

10. Requested permission for figure 8

New message ✕

Zayna Pieper ✕ +

Zayna Pieper
Functional Consultant at Oracle NetSuite

Use of images

Hi Zayna!

My name is Melissa Siver. I am a Photonic Engineering undergraduate student at the University of Central Florida. I am currently completing the first part of my capstone project, Senior Design I. We are required to write a paper detailing the steps taken during the planning of our project. I am writing to ask permission to use an image from your own senior design project, the [BioRhythm](#). The images will only be used in my paper and will not be published or otherwise used for profit of any kind.

Thanks for your time.
 |
 Melissa Siver

11. Requested permission for figure 5

Melissa Siver

mksiver@knights.ucf.edu

image usage

My name is Melissa Siver. I am a Photonic Engineering undergraduate student at the University of Central Florida. I am currently completing the first part of my capstone project, Senior Design I. We are required to write a paper detailing the steps taken during the planning of our project. I am writing to ask permission to use the image of your hand held spectrometer found here: <https://trinamixsensing.com/nir-spectroscopy/mobile-nir-spectroscopy-solutions/>. The images will only be used in my paper and will not be published or otherwise used for profit of any kind.

Thanks for your time,

Melissa Siver